

SAMPLING AND ANALYSIS PLAN

Section 2.0

Meteorology and Air Quality

APRIL 2009

Prepared for Roca Honda Resources, LLC
4001 Office Court, Suite 102, Santa Fe, NM 87507

Contents

2.0	Meteorology and Air Quality Monitoring.....	2-1
2.1	Introduction and Background	2-1
2.2	Sampling Objectives	2-2
2.3	List of Data to be Collected	2-2
2.4	Methods of Collection.....	2-2
2.4.1	Air Particulate Pump and Weather House	2-4
2.4.1.1	Air Particulate 47-mm Filter Exchanges.....	2-5
2.4.1.2	Air Filter Radioparticulate Analyses	2-6
2.4.2	Radon Detectors.....	2-7
2.4.3	Gamma TLD	2-8
2.5	Parameters to be Analyzed.....	2-10
2.6	Maps Providing Sampling Locations.....	2-10
2.7	Sampling Frequency	2-10
2.8	Laboratory and Field Quality Assurance Plan	2-10
2.8.1	Meteorological Station.....	2-11
2.8.2	Air Particulate Sampler.....	2-11
2.8.2.1	Sampler Calibration and Flow Checks	2-11
2.8.2.2	Records and Document Control.....	2-11
2.8.2.3	Data Review and Reporting	2-12
2.8.2.4	Sample Handling and Custody Requirements	2-12
2.8.3	Radon and Gamma Detectors	2-12
2.8.3.1	Detector Protection	2-12
2.8.3.2	Records and Document Control.....	2-13
2.8.3.3	Data Review and Reporting	2-13
2.8.3.4	Sample Handling and Custody Requirements	2-13
2.9	Brief Discussion Supporting Proposal	2-13
2.10	References.....	2-13

Figures

Figure 2-1.	Locations of Meteorological Station and Air Sampler - Draft.....	2-3
-------------	--	-----

Tables

Table 2-1.	Data Needs Identified for Meteorology and Air Quality Monitoring.....	2-2
Table 2-2.	Air Filter Radioparticulate Analyses	2-7

Appendixes

Appendix A	VS-Series Air Sampler Operations Manual
------------	---

Appendix B	Air Particulate Sampling Field Log
Appendix C	Completed Sample Chain-of-Custody Form
Appendix D	Radon Alpha Track Sampling Field Log
Appendix E	Exterior Radon Measurements Using Alpha Track Detector Procedures
Appendix F	Environmental Gamma TLD Sampling Field Log
Appendix G	Quarterly Air Sampler Calibration Log

2.0 Meteorology and Air Quality

2.1 Introduction and Background

Climate in the Roca Honda permit area, which is in the Ambrosia Lake uranium subdistrict of west-central New Mexico, may be classified as arid to semiarid continental, characterized by cool, dry winters and warm, dry summers. The area is in the north end of climate division 4 (Southwestern Mountains) for New Mexico (Sheppard et al. 1999). Abundant sunshine, low relative humidity, and large annual and diurnal ranges in temperature are characteristics of this climate division, which is a significant distance from any source of oceanic moisture (600 miles from the Pacific Ocean and 800 miles from the Gulf of Mexico).

Winter is the driest season, and what precipitation falls (mostly as snow) is from storms that form in the Pacific Ocean, move inland, and lose most of their moisture in the mountains of California and Arizona. Snow falls from December through March and is light on the valley floors, but increases at higher elevations of the nearby mesas and mountains. The estimated average annual snowfall is 26 inches for the San Juan basin (U.S. Department of Interior 1980).

The wettest period is in late summer and early fall. Approximately half of the annual precipitation in this region falls from July through September, which averages more than 50 days of brief thunderstorms per year. The storms are sometimes heavy and can be accompanied by hail and strong, gusty winds (Baldwin 1973). These storms may bring several inches of rain to small areas in a short time, and runoff frequently causes local flash floods. In addition, precipitation events lasting several days may occur occasionally in September and October when tropical storms move into the area from the Gulf of Mexico or the Gulf of California.

Estimates of relative humidity for this region from the soil survey of the McKinley County area show that relative humidity is highest in the early morning near dawn—approximately 70 percent in winter and 45 percent in summer—and in the evening near dusk falls to approximately 40 percent in winter and 15 to 20 percent in summer (NRCS 2006). June is usually the driest month, and mid afternoon relative humidity is typically less than 15 percent. In June, the sun shines approximately 80 to 85 percent of the time, while in the rest of the summer it shines approximately 75 to 80 percent of the time. In winter, sunshine drops to approximately 65 to 70 percent of the time.

The annual rate of potential evaporation is approximately 75 to 80 inches as measured by standard evaporation pans, shown for the region in the Ground Water Atlas of the United States, Segment 2 (Robson and Banta 1995). Net lake evaporation for the region is 30 to 40 inches per year (New Mexico Interstate Stream Commission and New Mexico Office of the State Engineer 2002).

Large-scale (or synoptic) winds in the region are most frequently from the southwest and west and are strongest between March and June, with the highest average speeds in March. Winds up to 60 miles per hour can accompany frontal activity associated with late winter and spring low pressure systems and thunderstorms. The strong spring winds often bring considerable dust into the area.

The Roca Honda Project is located in the Southwestern Mountains – Augustine Plains Intrastate Air Quality Control Region in Northwestern NM. The entire area has been classified by the U.S.

EPA as National Ambient Air Quality Standards (NAAQS) attainment area (EPA 2007a). Further, there are no Prevention of Significant Deterioration (PSD) Class I areas in Northwestern NM (EPA 2007b). Total suspended particulate matter (TSP) is an additional regulated air constituent of air quality concern in New Mexico. Natural sources of TSP in the area typically include wind-blown dust and vehicle traffic on unpaved roads.

2.2 Sampling Objectives

This SAP describes the sampling and analysis activities to be performed in conjunction with meteorological and air quality monitoring at the Roca Honda permit area. The objectives of the proposed monitoring activities are to characterize and establish baseline ambient air quality conditions and background radiological conditions at the Roca Honda permit area in advance of mining, and to supplement existing historical meteorological data. The instrumentation described in the following sections was installed in late 2007 and the data has been and continues to be collected in accordance with the procedures described below. Additional air quality sampling is planned to further establish background conditions. The sampling results will be reported in the updated Baseline Data Summary submitted with the Mine Permit Application.

2.3 List of Data to be Collected

Three data needs were identified for meteorology (Baseline Data Summary, Section 2.0, “Climatology”) and air quality monitoring to support NEPA analysis. They are identified in Table 2–1.

Table 2–1. Data Needs Identified for Meteorology and Air Quality Monitoring

Data Needs	Plan to Address Data Need
Air temperature, relative humidity, evaporation, precipitation, wind speed and direction, wind standard deviation, and barometric pressure	The Roca Honda Resources, LLC (RHR) meteorological station will gather data to support site operations.
Pre-operational ambient radon and gamma levels	Radon and gamma monitoring at fixed locations surrounding proposed operational areas.
Pre-operational ambient air quality levels	Air particulate collection and radioanalytical analysis. Installation and sample collection from Hi-Vol sampler.

2.4 Methods of Collection

Meteorological Monitoring

Roca Honda Resources, LLC (RHR) installed a meteorological station in Section 16 at the Roca Honda permit area in November 2007. The solar-powered station records air temperature (°F), relative humidity (percent), precipitation (millimeters [mm]), wind speed (meters [m] per second [m/s]), wind direction (degrees), wind direction standard deviation, evaporation (mm), and barometric pressure (millibars [mbar]) on an hourly basis.

All hourly parameters are stored in a Campbell Scientific CR1000 digital data logger and downloaded on a bi-weekly basis. The data are then reviewed for quality assurance/quality control and graphed as an X-axis time series in Excel or plotted on a wind rose diagram and reviewed. Data that appear to be suspect, outliers, or invalid are flagged and excluded from the graphed or plotted figures. Figure 2-1 indicates the locations of RHR’s existing meteorological station and air sampler.

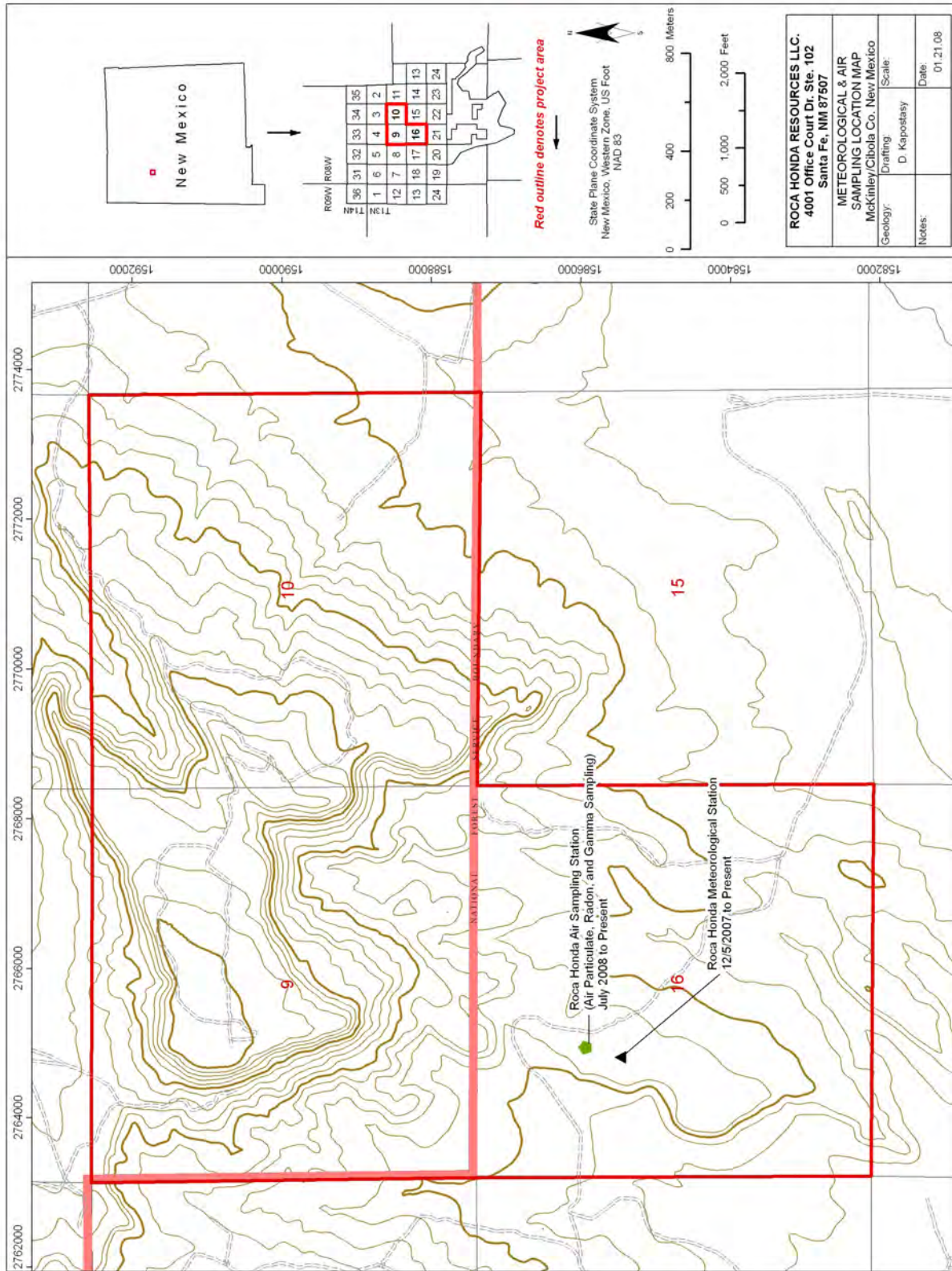

Figure 2-1. Locations of Meteorological Station and Air Sampler - Draft

Air Quality Monitoring

The national ambient air quality priority or criteria pollutants are ground-level ozone, particulate matter, carbon monoxide, lead, nitrogen dioxide, and sulfur dioxide. New Mexico's ambient air quality standards include all but ozone and lead. The national primary and secondary standards are similar in concentration limits and the New Mexico limits are also similar or slightly more stringent. The nearest existing monitoring station to the permit area is San Juan county near the Four Corners power plant. The monitoring results during a period from 1990 to 2007 (the actual period varies for each pollutant) show the levels below the required limits with the exception of ozone which has been at or below the limit since the year 2000 (station in Bloomfield).

Because the permit area is remote from any priority pollutant sources and not within a State Air Quality Maintenance Area, RHR has elected at this time to monitor for particulate matter and radiological constituents. Several hundred historic exploratory holes are located within the permit area. Drill cuttings, if left un-reclaimed on the surface of the ground, could potentially result in detectable radiation levels. While, unlikely, it is appropriate to include this possibility as part of the baseline air quality analysis.

Data from the Gulf Mt. Taylor Environmental Report (1979-drafted for the proposed uranium mill) indicated ambient particulate matter in the San Mateo Valley above ambient standards. Radiological data results were not reported and the trace metals were below limits. Total suspended particulate matter is monitored by others in the area and RHR proposes to install a Hi-Vol sampler at the location of the existing air quality samplers to further define the background conditions. Detailed information on the Hi-Vol installation, operation, calibration, and analytical methods will be included at a later time when the operational power supply at the site is determined. The ground radiological survey (Section 10 of this SAP) will identify potential areas of old drill hole cuttings from historical drill holes on the surface. Before mine operations RHR will obtain the required air permits and monitor for the constituents identified in the permit.

2.4.1 Air Particulate Pump and Weather House

Air particulates are collected on a 47-mm glass cellulose filter using a Hi-Q VS23-0523CV continuous duty, constant flow air sampler (Manufacturer's manual in Appendix A). The ¼-horsepower, oilless, rotary-vane air sampling system has a variable flow rate control of between 0.35 cubic feet per minute (cfm) to 4.5 cfm (10 to 127 liters per minute [lpm]). The pump is protected from the elements by a steel weather house with an external 3/8-inch quick-disconnect gooseneck air intake. The 47-mm filter sample holder is located outside of the weather house at an approximate height of 1.5 meters above the ground surface. The filter holder is protected from direct precipitation by a rain and wind shield. A resettable electronic timer (hours and tenths of an hour) is attached to the pump. The timer records the duration of operation of the pump and filter.

The 47-mm filters consist of high-efficiency particulate air (HEPA) 100 percent borosilicate glass microfibers with an acrylic resin binder. Ambient air is pulled through the filter by the vacuum created from the pump. A rotameter, attached to the side of the pump, indicates the volumetric flow rate of the air passing through the filter. The rotameter is a tapered metering tube with a float that measures the air flow, in cfm, through the filter holder. The beginning and ending flow rate and elapsed hours are recorded on the field forms to determine the total volume of air that has passed through the 47-mm filter media.

2.4.1.1 Air Particulate 47-mm Filter Exchanges

A supplemental filter holder is provided so that a new 47-mm filter can be mounted on the filter holder in the office, and the filter holder can be easily exchanged in the field using the 3/8-inch quick disconnects. The following narrative describes the steps to be followed in exchanging the 47-mm filters.

Filters will be changed on a weekly basis. A copy of a blank field sheet to document the field conditions, date, and time of the particulate filter exchanges is presented in Appendix B of this section of the SAP.

- Prior to leaving for the mine site, place a new filter in the supplemental filter holder by unscrewing the retaining ring to the filter holder and centering a new filter on the hexagonal screen backing with a pair of tweezers. The smooth face of the filter goes against the screen backing; the raised, nappy surface of the 47-mm filter faces out of the filter holder so that the exposed glass fibers entrap the airborne particulates. Snugly screw the retaining ring back over the filter holder without pinching or tearing the 47-mm filter media. Place the filter holder in a Ziploc-type bag for transport to the field.
- When in the field, verify the air pump unit is running and in good condition according to the manufacturer's requirements. If the unit is not running, conduct troubleshooting as per the manufacturer's manual provided in Appendix A of this section of the SAP.
- Record the date collected, sample number, ending flow rate, and hours and tenths (6 minutes) of an hour operation for the filter on the "Air Particulate Sampling Field Log" as provided in Appendix B of this section of the SAP.
- Remove the filter holder from beneath the stainless steel inverted rain and wind shield using the 3/8-inch quick-disconnect intake (push up on the connection to release the filter holder).
- Place the used filter and filter holder in plastic Ziploc-type bag for transport to the office. Mark the bag with the filter holder with the sample number and collection date.
- Connect the new filter holder to the air sampling unit using the 3/8-inch quick disconnect (push up on the connection and insert the male end of the filter holder).
- Reset the timer to zero (0).
- Record sample number, date, and initial flow rate.

The initial flow rate will be between 0.71 cfm and 1 cfm (20 lpm to 28.3 lpm). The flow rate may change up or down slightly depending on the amount of dust loading on the 47-mm filter media. A pump operating at 0.71 cfm for 8 days will have pulled approximately 8,179 cubic feet (ft³) (2.30×10^5 liters) of air through the filter. If the flow rate is outside the operating range, then field verification of the flow rate may be needed and recorded on the Air Particulate Sampling Field Log.

After returning from the field, unscrew the filter holder ring, use tweezers to remove the used filter from the filter holder, and place the filter in a Ziploc-type bag. Wipe away any dust from the exterior of the filter holder and from the hexagonal screen backing with a disposable wipe.

Snugly tighten the ring back on the filter holder and place in a clean Ziploc-type bag for storage until the next weekly sampling event.

2.4.1.2 Air Filter Radioparticulate Analyses

Standard procedures for sample handling, packaging, shipping, and chain of custody (COC) will be followed for the preparation of samples for shipment to the off-site analytical laboratory. The exposed filters are placed in a Ziploc-type bag, and a sample label is completed and placed on the outside of the bag. A COC form is prepared and shall accompany the filter(s) at all times. The COC must identify the sample identification number, sample collection date and time, and requested analyses. A completed sample COC is presented as a guide in Appendix C of this section of the SAP.

Sample labeling of the weekly filters will be as follows:

Mine Site-Station ID-Year-Month-Day-Media

Thus sample number “RH-1-2008-03-12-F” is a 47-mm filter sample from the Roca Honda permit area that was collected from Station 1 on March 12, 2008. Numbering and labeling samples in this format will allow for each sample number to be unique and discernible from other like samples. Subsequent filter samples will numerically change to reflect the year, month, and day of sample collection.

The weekly 47-mm filter will be retained by RHR in a secure location at the Grants, New Mexico office until the last weekly sample for the month is collected. The weekly samples for the monthly time period plus a completed COC will then be shipped overnight for radioparticulate activity analyses. Tested parameters on the weekly filter(s) will initially include gross alpha and gross beta screening. The weekly filters that are submitted monthly will be composited for quarterly (January through March; April through June; July through September; and October through December) digestion for radium (Ra-226), thorium isotopes (Th-228, Th-230, Th-232), and total uranium (U) radiochemical activity analyses.

Sample labeling of the composited quarterly filters will be as follows:

Mine Site-Station ID-Year-Quarter (QTR)-Number

Thus sample number “RH-1-2008-QTR-1” is a composite of all weekly 47-mm filter samples collected from Station 1 during the first calendar quarter of 2008 (January through March) from the Roca Honda permit area. Numbering and labeling samples in this format will allow for each sample number to be unique and discernible from other like samples. Subsequent composite filter samples will numerically change to reflect the year and calendar quarter that the composited samples are being analyzed.

Analytical parameters, laboratory methods and sample turnaround times (TAT) for radioparticulate analyses are summarized in Table 2–2. A hard copy and electronic version of the activity analytical results will be reviewed by the database manager, prior to inclusion of the data into the RHR database.

Table 2–2. Air Filter Radioparticulate Analyses

Parameter	Method	Minimal Detectable Concentration	TAT (days)
Gross Alpha/Beta	900 DC	3 pCi/sample/ 4pCi/sample	14
Radium (Ra-226)	903.1	4.0 pCi/sample	30
Thorium (Th-230)	D3972-90M	1.0 pCi/sample	30
Total Uranium (U)	D3972-90M	0.4 pCi/sample	30

pCi = picocuries

2.4.2 Radon Detectors

Radon concentrations are measured using alpha-track detectors. The passive alpha-track detector is packaged and shipped in aluminum-foil bags that prevent exposure prior to use. Three detectors (one sample plus two duplicates) are used to determine baseline alpha activity at the Roca Honda permit area. The detector is contained within a protective white canister for outdoor use. The detectors are mounted on a fence post and are collocated in the immediate vicinity of the particulate air sample pump.

The alpha-track detectors will be changed on a quarterly basis. A copy of a blank field sheet to document the date, serial number, sample number, and field conditions is presented in Appendix D of this section of the SAP.

The alpha-track detector consists of a radiosensitive element that records alpha particle emissions (alpha tracks) from the natural radioactive decay of radon. Each detector is sealed in a foil envelope for protection from transit exposure. The foil bag is not to be opened until the cups are ready to be deployed in the field. Copies of the serial numbers of the detectors are taped to the exterior of the foil envelope and are barcode readable. When deployed in the field, the serial numbers of the detectors must be verified against the serial numbers taped to the exterior of the foil envelope. Serial numbers of the detectors will be recorded in the air monitoring field logbook.

The alpha-track detector is placed in the protective white canister by removing the two wing nuts and the clear plastic retaining disk on the bottom of the canister. The detector is placed in the clear plastic cup and secured to the Velcro tab on the bottom of the cup. The clear plastic cup is placed back inside the protective white canister with the open end of the cup facing down. The clear plastic retaining ring is then reattached to the canister using the two wing nuts. The open holes of the detector should be facing the ground surface.

Two weeks before the allotted time period for the quarterly exposure of the alpha-track detectors, the vendor will be contacted, and another set of three detectors for the upcoming quarter ordered. Upon receipt of the new quarter alpha-track detectors, the serial numbers will be recorded in the air monitoring field logbook.

At the time of alpha-track detector sample collection, the 1 3/8-inch metal foil circle is placed over the open holes of the exposed detectors to seal the detectors from any exposure to radon during transit. When the alpha-track detectors are returned to the laboratory, the alpha tracks are counted using computer-assisted image analysis equipment. The number of alpha tracks along with the deployment time period provides the basis for calculating the average radon concentration. The report presents the radon gas measurements in picocuries per liter of air.

Sampling and documentation of the alpha-track detectors will be performed as specified in Appendix E of this section of the SAP. As the Roca Honda air monitoring program progresses additional radon cups that are from the same vendor batch number will be purchased and stored in a charcoal-lined, radon-free storage container (Rangel, et al., 1988).

Sample labeling of the alpha-track detectors will be as follows:

Mine Site-Station ID-Year-Month-Day-Detector Label

Therefore, sample number “RH-1-2008-03-12-A” is the primary detector from the Roca Honda permit area that was collected from Station 1 on March 12, 2008. The secondary (B and C) duplicate detectors will be labeled accordingly. Numbering and labeling samples in this format will allow for each sample number to be unique and discernible from other like samples. Subsequent alpha-track detector samples will numerically change to reflect the month and day of sample collection; the primary (A) and secondary (B and C) detector labeling format will remain the same.

After 1 year of sample collection, the number of alpha-track detectors that are mounted on the fence post may be reduced to only one (A), pending a review of the analytical data and the variance between sample detectors A through C per quarter.

Field data (e.g., detector serial number, sample location, date and time of deployment, date and time of retrieval, condition of detector upon retrieval [cracked, broken, damaged], and serial number verification for individual radon monitoring locations) will be collected and maintained in the air monitoring field logbook.

A hard-copy and electronic version of the activity analytical results will be reviewed prior to the inclusion of the data into the Strathmore database.

2.4.3 Gamma TLD

Gamma activity is measured using passive thermoluminescent dosimeters (TLDs). The environmental TLDs selected for this project will be collocated with the radon alpha-track detectors on the same fence post. The analyses of the environmental TLD 110 dosimeter will be conducted by the supplier. The gamma TLDs will be changed on a quarterly basis. A copy of a blank field sheet to document the date, serial number, sample number, and field conditions is presented in Appendix F of this section of the SAP.

The environmental dosimeter is designed for outdoor usage and is used to determine baseline conditions and to monitor gamma activity during mining operations. The dosimeter is encased in a polypropylene holder for weather resistance. The lower limit of detection is 10 millirem (mrem) per quarter.

A transit control dosimeter will accompany the sample environmental dosimeter that will be placed in the field. The purpose of the transit control dosimeter is to account for any potential gamma radiation exposures to the sample environmental dosimeter during transit. The transit control dosimeter will be placed in a shielded container while the environmental dosimeter is in use in the field (3 months). The transit control dosimeter then accompanies the environmental dosimeter back to the laboratory where both dosimeters are analyzed and any activity identified on the transit control dosimeter will be accounted for in the analytical report. The analytical

results on the environmental dosimeter can then be flagged if the transit control dosimeter indicates elevated activity readings.

The two dosimeters are shipped to the laboratory for analysis. The packing list that accompanies the dosimeters identifies the dosimeter serial number that corresponds to the transit control dosimeter and the environmental dosimeter. The transit control dosimeter is stored in a plastic bag labeled “Control – Do Not Open – Do Not Assign.” The serial numbers on the back of the dosimeters should be verified to the packing list. The serial numbers of the dosimeters will be recorded in the air monitoring field logbook. The transit control dosimeter will be stored in the lead-lined container while the environmental dosimeter is attached to the fence post in the field.

Two weeks before the allotted time period for the quarterly exposure of the environmental dosimeter, the vendor will be contacted and another pair of dosimeters for the following quarter ordered. Upon receipt of the new quarter dosimeters, the serial numbers of the dosimeters will be recorded in the air monitoring field logbook.

When the dosimeters are exchanged at the end of the calendar quarter, the transit control dosimeter will be brought into the field in the lead-lined container and then placed in the return envelope with the exposed environmental dosimeter. The new quarterly environmental dosimeter is then mounted on the fence post, and the new transit control dosimeter is placed in the lead-lined container. The dosimeters in the return envelope are then forwarded to the lab for activity analysis.

Sample labeling of both the transit control and sample environmental dosimeters will be as follows:

Mine Site-Station ID-Year-Quarter (QTR)-Dosimeter

Thus sample number “RH-1-2008-QTR-1-Environmental” is the sample environmental dosimeter badge from Roca Honda permit area that was collected from Station 1 on or about March 31, 2008, at the end of the first calendar quarter for 2008. The transit control dosimeter activity results will be similarly identified with the label “Control” as a suffix. Numbering and labeling samples in this format will allow for each sample number to be unique and discernible from other like samples. Subsequent TLDs will numerically change to reflect the year and calendar quarter of sample collection.

Field data (e.g., TLD model and serial numbers, sample location, date of deployment, date of retrieval) for individual gamma monitoring locations will be collected and maintained in the air monitoring field logbook.

Activity results will be identified as reported as gross results. A hard copy and electronic version of the activity analytical results will be reviewed by the database manager prior to the inclusion of the data in the Strathmore database.

2.5 Parameters to be Analyzed

Meteorological Parameters

The solar-powered station records air temperature (°F), relative humidity (percent), precipitation (millimeters [mm]), wind speed (meters [m] per second [m/s]), wind direction (degrees), wind direction standard deviation, evaporation (mm), and barometric pressure (millibars [mbar]).

Air Quality Parameters

Air quality parameters to be monitored at the Roca Honda permit area include TSP, radon, radioactive particulates, and direct gamma radiation levels.

2.6 Maps Providing Sampling Locations

Figure 2-1 identifies the location of the meteorological station. Baseline air quality data will be collected from one air quality monitoring station, to include the proposed Hi-Vol sampler, located just north of the meteorological station, also depicted in Figure 2-1.

2.7 Sampling Frequency

Meteorological Station

The solar-powered station records the specific data on an hourly basis to a digital data logger and downloaded on a bi-weekly basis.

Air Quality Station

Air particulates are collected on a continuous duty, constant flow air sampler. Filters will be changed on a weekly basis. The proposed Hi-Vol sampler filters will be changed at the same frequency.

Radon concentrations are measured using alpha-track detectors. The detectors will be changed on a quarterly basis.

Gamma activity is measured using passive TLDs. The TLDs will be changed on a quarterly basis.

2.8 Laboratory and Field Quality Assurance Plan

Quality control during air sampling will be achieved by implementing and adhering to guidance in the *Quality Assurance Handbook for Air Pollution Measurement Systems, Volume III* (EPA 1994). Guidance in this handbook includes calibration procedures, quality control flow rate checks, independent performance audit checks, filter handling protocol, laboratory quality control, personnel chain of command, and data validation protocol.

Laboratories used for the analysis of air monitoring filters, radon detectors, and gamma dosimeters will have a documented Quality Assurance (QA) program and will follow relevant laboratory procedures. QA program requirements and rights of access for verification of QA program implementation will be applied to subcontracted laboratories through the appropriate

procurement documents. Analytical quality control will include, as appropriate, the analysis of blanks, duplicates, control, and surrogate samples as specified by the method.

The RHR field personnel will be trained to the equipment operation, sample collection, preservation, and shipping procedures, and the documentation. This QA section is subdivided into the quality steps related to the meteorological station, air particulate sampler, and radon and gamma detectors.

2.8.1 Meteorological Station

There is no analytical laboratory required for this type of data collection. The station equipment was installed by an experienced contractor who then trained a RHR Field Leader in the equipment operation and the data downloading process. Parameters in the meteorological data set that monitor the condition of the field equipment include battery voltage maximum, minimum, and average; solar panel temperature (°C); and wind sensor error detector (n_TOT – 7200 qualifying number). These parameters are monitored to assess the functionality of the equipment and determine if there is a specific period of time when a malfunction in the wind sensor, possibly due to ice buildup, has been detected. The Field Leader checks the data with the National Oceanic and Atmospheric Administration Weather station at the Grants, New Mexico airport to look for suspect data. The equipment checks and data download visits are recorded in the project logbook and filed as a quality document in Strathmore's Santa Fe, NM office.

2.8.2 Air Particulate Sampler

2.8.2.1 Sampler Calibration and Flow Checks

The Hi-Q low volume air pump sampler will initially be checked with the V-FLO-5 Venturi flow meter to assure it is operating properly. The air pump sampler and rotameter will be recalibrated quarterly with the NIST traceable air flow meter or when the operating parameters are out of range. A good time to conduct the flow verification is when the last bi-weekly 47-mm air filter sample for the quarter is removed from the particulate sampler. The V-FLO-5 calibration unit will be returned to the manufacturer every two years to ensure the unit is within the NIST standards. Procedures for the quarterly field calibration check are presented in Appendix F. Appendix F also provides the operation manual and vendor specification sheets of the VS-Series Air Sampler, troubleshooting matrix, and calibration certification. A Quarterly Air Sampler Calibration Log (Appendix G of this section of the SAP) documents the date, flow rates observed on the air pump rotameter and the V-FLO-5 calibrated unit, and the adjusted flow rate should the air sampler pump be out of calibration. The calibration records and forms will be retained in the project files.

2.8.2.2 Records and Document Control

All entries in the air monitoring field logbook will be made with indelible ink and will be legible, accurate, complete, and traceable to the sample measurements and/or site location. Field logbook data are intended to provide sufficient data and observations to enable participants to reconstruct events that occurred during the field sampling activities. Field logbooks will be stored such that they are protected from loss or damage and will become part of the permanent Roca Honda permit area record file. The air monitoring field logbook will be maintained by the RHR environmental project manager or designee.

A copy of each COC form will be retained for traceability in case the sample is lost or destroyed. The copy received by the subcontracted laboratory will be included in the final analytical reports. All information/data gathered during the course of the fieldwork will be maintained in the project record file. If an error is made when recording field data, the method of correction will be to draw a single line through the error and enter the correct information. All corrections will be initialed and dated. The erroneous information will not be obliterated. When practical, any subsequently discovered error will be corrected by the person who made the entry. All corrections will be initialed and dated.

2.8.2.3 Data Review and Reporting

Data collected during field sampling activities and reported by the laboratories will be entered into a data management system (DMS) maintained by RHR. If quarterly calibration requires greater than 10 percent flow adjustment to the low-flow sampler and results are above background level, data will be flagged with an appropriate data quality flag. RHR will use the processed data to update the Baseline Data Summary.

2.8.2.4 Sample Handling and Custody Requirements

Sample handling and COC procedures will be strictly followed during sample collection, transportation, and laboratory handling to assure the identity and integrity of the samples. Improper sample and data handling and inadequate COC procedures affect the credibility and acceptability of analytical results, regardless of their accuracy or precision.

All samples will be appropriately labeled with the sample identification nomenclature as previously identified. Each label will include project name, time and date of collection, sample location or other distinguishing sample identification number, and the initials of the sampler. The COC record will be initiated by the field sampling personnel upon collection of a sample and will accompany each shipping container. The sampling personnel will retain a copy of the COC record and send the original with the sample shipment. The COC forms will be retained in the project files.

Samples will be properly packaged in shipping containers to ensure the integrity of the samples. Shipping containers will be transported via courier to the laboratory. Each person who has the samples in his or her possession, including couriers (except Federal Express), will sign the COC record. Upon sample receipt at the laboratory, any deficiencies identified by the laboratory will be documented on the COC record and the RHR Quality Assurance Manager (or designee) will be notified for necessary resolution.

2.8.3 Radon and Gamma Detectors

2.8.3.1 Detector Protection

The RHR Field Leader or his designee will be trained in the handling and installation procedures for the radon alpha-track detectors and the gamma TLDs. When the detectors are received from the vendors, they will be checked to ensure the packaging is secure to prevent prior exposure. The new TLDs will be kept in lead-lined containers until they are mounted. The control TLD will also be kept shielded until it is returned to the laboratory with the test exposed TLD. The radon and gamma detectors will be mounted on the same post at the station near the air sampler. The radon detectors will be placed in a set of three which provides data verification. The Field

Leader ensures the detectors are labeled properly to include their serial numbers and records the numbers, installation date, and any other site information in the official logbook. The detectors are collected on a quarterly basis and packaged for shipment to the analytical laboratories. The Field Leader or designee completes the COC and ensures the handling and shipping procedures are followed and documented.

2.8.3.2 Records and Document Control

The logbook procedures discussed in Section 2.4 will be followed for the radon and gamma detector installation and collection. The same logbook will be used for the air monitoring field work. Two different laboratories will be used for the radon and gamma analyses and they will be different from the air particulate analytical laboratory. Therefore, the COC forms are different and will be filed separately in the overall air monitoring field effort.

2.8.3.3 Data Review and Reporting

Data collected during field sampling activities and reported by the laboratories will be entered into a DMS managed by RHR. The relevant technical staff will use the data to update the Baseline Data Summary.

2.8.3.4 Sample Handling and Custody Requirements

The sample handling and custody requirements discussed in Section 2.4 will be followed for the radon and gamma detectors.

2.9 Brief Discussion Supporting Proposal

The objectives of the proposed monitoring activities are to characterize and establish baseline ambient air quality conditions and background radiological conditions at the Roca Honda permit area in advance of mining.

Data from the onsite meteorological station will be used to supplement existing historical meteorological data for engineering calculations involving floods, evaporation potential for ponds, sampling of surface water runoff, and other applications. Historical data was found from meteorological stations operated by the National Weather Service and Gulf Mineral Resources in support of baseline data collection for the area from 1918 through 1988.

2.10 References

Baldwin, J.L., 1973. *Climates of the States*, U.S. Department of Commerce, National Oceanic and Atmospheric Administration, Washington, D.C.

EPA (U.S. Environmental Protection Agency), 1994. *Quality Assurance Handbook for Air Pollution Measurement Systems, Volume III: Part I, Ambient Air Quality Monitoring Program Quality System Development*, EPA-454/R-98-004, August.

EPA, 2007a. *Counties Designate Nonattainment or Maintenance for Clean Air Act's National Ambient Air Quality Standards, 2007a*.

EPA, 2007b. *Prevention of Significant Deterioration Permit Program Status, 2007b*.

New Mexico Interstate Stream Commission and New Mexico Office of the State Engineer, 2002.

NRCS (Natural Resources Conservation Service), 2006. *Soil Survey of McKinley County Area, NM, McKinley County and Parts of Cibola and San Juan Counties*, U.S. Department of Agricultural, Natural Resources Conservation Service, in cooperation with U.S. Department of Interior, Bureau of Land Management and Bureau of Indian Affairs, and the NM Agricultural Experimental Station.

Rangel, M. J., M. D. Pearson, and G. H. Langner, Jr., 1988, “Radon-Free Chamber” in Abstracts of Papers Presented at 33rd Annual Meeting of the Health Physics Society, Boston, Massachusetts, July 4-8, Pergamon Press, New York, NY.

Robson, S.G., and E.R. Banta, 1995. *Ground Water Atlas of the United States, Segment 2-Arizonia, Colorado, New Mexico, and Utah*, U.S. Geological Survey Hydrologic Investigations Atlas 730-C.

Sheppard et al., 1999. *The Climate of the Southwest, Institute for the Study of Planet Earth*, CLIMAS Report Series CLI-99.

U.S. Department of Interior, 1980. *Uranium Development in the San Juan Basin Region-A Report on Environmental Issues, final edition*, San Juan Basin Regional Uranium Study, Office of Trust Responsibilities, Bureau of Indian Affairs, Albuquerque, NM.

Appendix A

VS-Series Air Sampler Operations Manual

HI-Q Environmental
Products Co.
Division of La Jolla Scientific Co., Inc.

7386 Trade Street
San Diego, California 92121-2422

Phone: 858-549-2820
Fax: 858-549-9657
www.HI-Q.net

VS-SERIES AIR SAMPLER

VS23-0523CV
S/N: 17284

Rev.N.R 01/04

1/9/2008

Dear Customer,

HI-Q Environmental Products Company appreciates the opportunity to supply you with the highest quality air sampling equipment on the market today. Please do not hesitate to contact us with any comments or questions regarding our line of air sampling systems and accessories. This will help us continue to provide you and your colleagues with new and improved products necessary in this era of environmental monitoring concerns and needs.

Thank you for your continued patronage,

HI-Q Environmental Products Company

Table of Contents

<u>DESCRIPTION</u>	<u>PAGE</u>
Maintenance & Operating Instructions	4-5
Filter Holders	6
Operation Instructions	7
Calibration	7
Optional Electronic, Resettable, Elapsed Timer	7
Field Calibration	7
Spare Parts List	8
<u>DETAILED VENDOR SPECIFICATION SHEETS</u>	
Vendor Vacuum Pump Specification Sheet	9-17
Vendor Flowmeter Specification Sheet	18-19
Wiring Diagram	20
Equipment Outline Drawing	21
Instrument Calibration Certification	22
Calibration Instructions	23
Correction Factor Look-Up Table	24-25

MAINTENANCE & OPERATING INSTRUCTIONS

HI-Q's VS-Series, continuous duty, rotary vane air sampling systems are designed either to be incorporated as the primary vacuum source in air monitoring instrumentation or used by themselves for the collection of air borne particulate and/or gases. The systems are furnished complete with a shock mounted base rotary vane motor/pump, carrying handle, heavy duty constant air flow control valve (MCV-260), venturi flow meter, exhaust muffler, 8 foot grounded power cord, and a 3/8" female quick disconnect for easy filter holder change-out.

HI-Q's MCV-260, heavy duty control valve, is designed to maintain a constant air flow rate through a sample collection media for extended sampling periods.

HI-Q stocks anodized aluminum combination paper/cartridge and paper only filter holders for paper sizes of 47mm, 2", and 4" diameter and standard HI-Q TC, TCAL, and TCGA series cartridges.

Check HI-Q's latest catalog for additional options (elapsed timers, vacuum gauges, multiple inlets, ...) which can be supplied with any of the VS Series air sampling systems.

Flow Selection

The heavy duty control valve is easily set for a desired flow rate by removing the valve cover and adjusting the spring tension on the regulator. The flow rate can be controlled up to 0.6 CFM for the VS23-0531CV, 2.5 CFM for the VS23-3032CV, 4.5 CFM for the VS23-0523CV, 8.5 CFM for the VS23-1023CV, and 13 CFM for the VS23-1423CV unit. The V-FLO-XX venturi-flow meter, supplied with each unit, is an instantaneous visual indicator of the flow rate of air being pulled through the sample inlet. The V-FLO-XX unit is calibrated in-line against a secondary NIST traceable standard and should be accurate within +/-5% at the time of calibration.

Air Mover

The air mover is a rotary vane pump which is designed for continuous operation. The pump will deliver up to the aforementioned free air capacity and develop a suction head of 26" Hg maximum vacuum (20" Hg maximum vacuum for the VS23-0531CV). The oilless, carbon vane pumps require no lubrication.

Optional Filter Holders

For ambient (open faced) air sampling, HI-Q recommends using either the **RVH**-Series, combination cartridge & paper filter heads, or the **RVPH**-Series, paper only filter head. Each series come complete with a 3/8" male quick disconnect (1/4" Quick Disconnects for the VS23-0531CV).

For Stack, Duct, Fume Hood, or Glove Box air sampling, HI-Q recommends any of its "IL"-series, in-line holders. **ILFH**-Series for in-line combination type applications, and the **ILPH**-Series for in-line paper only applications.

The combination and paper only holders are easily removed by the use of the quick-disconnect coupling. Many technicians find it efficient to have at least two filter holders per sampling station, minimizing down-time by allowing entire used filter head assembly to be swapped out and sent to the lab while the employing a fresh new holder. Anti-Static Sample saver covers for the holders are available through HI-Q, #PC-767.

See the following page for filter holder descriptions.

Filter Holders

COMBINATION OPEN FACED

Model	Paper Size Diameter	Cartridge Type Series	Inlet Fitting	Outlet Fitting
RVH-20	2"	TC	Open Face	3/8" MQD
RVH-25	47mm	TC	Open Face	3/8" MQD
RVH-30	2"	TCAL	Open Face	3/8" MQD
RVH-35	47mm	TCAL	Open Face	3/8" MQD
RVHGA-30	2"	TCGA	Open Face	3/8" MQD
RVHGA-35	47mm	TCGA	Open Face	3/8" MQD

PAPER ONLY OPEN FACED

Model	Paper Size Diameter	Cartridge Type Series	Inlet Fitting	Outlet Fitting
RVPH-20	2"	N/A	Open Face	3/8" MQD
RVPH-25	47mm	N/A	Open Face	3/8" MQD
RVPH-102	4"	N/A	Open Face	3/8" MQD

IN-LINE COMBINATION HOLDERS

Model	Paper Size Diameter	Cartridge Type Series	Inlet Fitting	Outlet Fitting
ILFH-20	2"	TC	3/8" FQD	3/8" MQD
ILFH-22	2"	TCAL	3/8" FQD	3/8" MQD
ILFH-25	47mm	TC	3/8" FQD	3/8" MQD
ILFH-27	47mm	TCAL	3/8" FQD	3/8" MQD

IN-LINE PAPER ONLY HOLDER

Model	Paper Size Diameter	Cartridge Type Series	Inlet Fitting	Outlet Fitting
ILPH-20	2"	N/A	3/8" FPT	3/8" MQD
ILPH-47	47mm	N/A	3/8" FPT	3/8" MQD
ILPH-5	47mm	N/A	1/2" FPT	3/8" MQD
ILPH-13	47mm	N/A	3/4" FPT	3/8" MQD
ILPH-17	47mm	N/A	1" FPT	3/8" MQD

See current catalog for specific holder components and custom holders

OPERATING INSTRUCTIONS

TO START UNIT: Plug in set the flow rate, the unit is packed ready to operate. **Do not** add oil.

Calibration

All VS-Series Air Sampling systems are delivered to the customer pre-calibrated against an NIST traceable source. It is advised, however, to check final flow calibration frequently after the initial break-in period of 30 days. Bi-annual re-calibration services are offered by HI-Q. For re-calibration, it is not necessary to send in the entire pump system, simply disconnect the venturi-rotometer assembly from the threaded intake and send in.

Optional Electronic, Resettable, Elapsed, Timer

As an option HI-Q offers an electronic, resettable, elapsed timer that indicates on an LCD display the elapsed sampling time in hours and tenths (or minutes and tenths). The timer is wired into the pump and starts when the unit is turned on. The timer holds the total elapsed sample time. The timer is re-set to zero by pressing the re-set button. The timer has its own internal 10 year battery which makes it independent from the supply voltage and the cyclic rate. All running time readings are maintained even after the unit is turned off either deliberately, or due to loss of power. This optional feature eliminates the need to install an event meter or chart recorder. Without totalizer readout, the total sample collected will be the flow rate setting multiplied by the minutes of running time.

Field Calibration

Remove the paper retaining ring of the filter head and attach an in-line adapter cone with slip fitting (HI-Q LVSA-Series). Next, attach a calibration source (AFC-3 OR AFC-5 is ideal) in-line, upstream from the filter holder and pump.

Remove the cover from the regulator valve and adjust the spring tension until the desired flow is indicated by the rotometer.

Should any major discrepancy develop between the calibration source and the rotometer, place a piece of tape on the left side of the rotometer and mark the correct scale on it with a pen.

The unit will maintain this flow over a long period of time, although a periodic check is advisable. This constant flow will be maintained regardless of the filter paper used, as the regulator will permit only the predetermined flow up to the pumps operating capacity.

**Recommended Spare Parts List
VS23-SERIES**

PART NUMBER	DESCRIPTION
VS23CV-001	1/4 HP, 115/230 VAC, REPLACEMENT PUMP/MOTOR
VS23CV-002	3/4 HP REPLACEMENT PUMP/MOTOR 1023 SERIES
VS23CV-003	V-FLO-4, 0-4 CFM CALIBRATED VENTURI AND FLOWMETER
VS23CV-004	V-FLO-8, 0-8 CFM CALIBRATED VENTURI AND FLOWMETER
VS23CV-005	MCV-260, HEAVY DUTY, AUTOMATIC FLOW CONTROL VALVE
VS23CV-006	MCV-RK, REBUILD KIT FOR THE MCV-260
VS23CV-007	SERVICE REPAIR KIT FOR THE 0523-101Q-G588DX, K478
VS23CV-008	SERVICE REPAIR KIT FOR THE 1023-101Q-G608X PUMPS, K479
VS23CV-009	8' POWER CORD, 16/3 FOR 0523 SERIES PUMP
VS23CV-010	8' POWER CORD, 14/3 FOR 1023, 1423 SERIES PUMPS
VS23CV-011	ROTORMETER, UNCALIBRATED
VS23CV-012	BLANK SCALE FOR ROTORMETER
VS23CV-013	NEEDLE VALVE FOR ROTORMETER
VS23CV-014	HANDLE FOR 0523-SERIES PUMP/MOTOR
VS23CV-015	HANDLE ASSEMBLY FOR 1023, 1423 SERIES PUMP/MOTOR
VS23CV-016	BST-3M, 3/8" FEMALE QUICK DISCONNECT 3/8" MPT
VS23CV-017	SINTERED BRONZE MUFFLER FOR THE 0523 SERIES PUMP
VS23CV-018	SINTERED BRONZE MUFFLER FOR THE 1023, 1423 SERIES PUMP
VS23CV-019	FELT FILTER, 0523, 1023, 1423 SERIES PUMPS (2 REQUIRED)
VS23CV-020	REPLACEMENT VANE FOR 0523 SERIES MOTORS (4 REQUIRED)
VS23CV-021	REPLACEMENT VANE FOR 1023 SERIES MOTORS (4 REQUIRED)
VS23CV-022	"O" RING FOR 0523, 1023, 1423 SERIES PUMPS (2 REQUIRED)
VS23CV-023	MOTOR GASKET FOR 0523 SERIES PUMP (1 REQUIRED)
VS23CV-024	MOTOR GASKET FOR 1023 SERIES PUMPS (1 REQUIRED)
VS23CV-025	VS23-1023CV, VS23-1423CV SERIES FOOT (4 REQUIRED)
VS23CV-026	PLASTIC END CAP ASSEMBLY W/ FELT FILTER & O-RING (2RQD)
VS23CV-027	FELT FILTER FOR IN/OUT. 2-REQUIRED
VS23CV-028	EETXX-B MOTOR WIRE HARNESS. MOTOR SIDE.
VS23CV-029	1 HP REPLACEMENT PUMP/MOTOR 1423 SERIES
VS23CV-030	V-FLO-13, 0-13 CFM CALIBRATED VENTURI AND FLOWMETER
VS23CV-031	SERVICE REPAIR KIT FOR THE 1423-101Q-G628X PUMPS, K575A
VS23CV-032	1/4" BRASS ELBOW: 1/4" FNPT X 1/4" FNPT (2 rqr per 1/4 HP pump assmby)
VS23CV-033	3/8" MNPT X 1/4" MNPT STEEL HEX REDUCER (btw MCV-260 & 1/4" Elbow)
VS23CV-034	3/8" MNPT X 1" LONG FULL THREAD STEEL. (units w/o timer)
VS23CV-035	3/8" HEX NUT USED WITH UNITS (units w/ timer)
VS23CV-036	1/4" X 1" LONG FULL THREAD (used between first & second 1/4" elbow)
VS23CV-037	1/8" HOSE BARB X 1/8" MNPT. (3 used per sampler. Venturi tube & rotomtr)
VS23CV-038	1/4" X 1/4" STEEL HEX NIPPLE (used between 1/4 HP pump inlet & first 1/4 elbow)

PART NO. 70 - 290 G375PL (REV-G)

23 SERIES OIL-LESS VACUUM PUMPS & COMPRESSORS

OPERATION & MAINTENANCE MANUAL



Model #0523-101 Shown



Model #1023-V103 Shown



Model #1023-101Q Shown

Thank you for purchasing this Gast product. It is manufactured to the highest standards using quality materials. Please follow all recommended maintenance, operational and safety instructions and you will receive years of trouble free service.

IMPORTANT: PLEASE READ THIS MANUAL AND SAVE FOR FUTURE REFERENCE.

General Information

- **Clearances:** Top: .002"
Ends: .0015" - .005"
- **Vane Life:** 5,000-15,000 hours depending upon application

- **Model numbers ending in "X"** have automatic thermal protectors which protect the motor by shutting the motor off if it overheats. The motor will automatically restart once the motor has cooled.

Product Use Criteria:

- Pump only clean, dry air.
- Operate at 32°F - 104°F (0°C - 40°C).
- Protect unit from dirt & moisture.
- Do not pump flammable or explosive gases or use in an atmosphere that contains such gases.
- Protect all surrounding items from exhaust air. This exhaust air can become very hot.
- Corrosive gases and particulate material will damage unit. Water vapor, oil-based contaminants or other liquids must be filtered out.
- Consult your Gast Distributor before using at high altitudes.

- Oil-Less rotary-vanes require NO lubrication.
- Sealed bearings are grease packed
- Use of petroleum or hydrocarbon products will reduce carbon-vane service life.

Your safety and the safety of others
is extremely important.

We have provided many important safety messages
in this manual and on your product. Always read
and obey all safety messages.

 This is the safety alert symbol. This symbol
alerts you to hazards that can kill or hurt you and
others. The safety alert symbol and the words
"DANGER" and "WARNING" will precede all safety
messages. These words mean:

DANGER

You will be killed or seriously injured if you don't
follow instructions.

WARNING

You can be killed or seriously injured if you don't
follow instructions.

All safety messages will identify the hazard, tell you
how to reduce the chance of injury, and tell you
what can happen if the safety instructions are not
followed.

INSTALLATION

WARNING



Electrical Shock Hazard

Disconnect electrical power at the circuit breaker
or fuse box before installing this product.

Install this product where it will not come into
contact with water or other liquids.

Install this product where it will be weather
protected.

Electrically ground this product.

Failure to follow these instructions can result in
death, fire or electrical shock.

Correct installation is your responsibility. Make sure
you have the proper installation conditions and that
installation clearances do not block air flow.

Blocking air flow over the product in any way can
cause the product to overheat.

Mounting

This product can be installed in any orientation.
Mounting the product to a stable, rigid operating surface
and using shock mounts will reduce noise and vibration.

Plumbing

Remove plugs from the IN and OUT ports. Connect
with pipe and fittings that are the same size or larger
than the product's threaded ports.

Accessories

The product's intake and exhaust filters will provide
adequate filtration in most applications. Consult your
Gast representative for additional filter
recommendations. Install relief valves and gauges at
inlet or outlet, or both, to monitor performance. Check
valves are required to prevent back streaming through
the pump.

Motor Control

It is your responsibility to contact a qualified
electrician and assure that the electrical installation is
adequate and in conformance with all national and local
codes and ordinances.

Determine the correct overload setting required to
protect the motor (see motor starter manufacturer's
recommendations). Select fuses, motor protective
switches or thermal protective switches to provide
protection. Fuses act as short circuit protection for the
motor, not as protection against overload. Incoming line
fuses help to withstand the motor's starting current.
Motor starters with thermal magnetic overload or circuit
breakers protect motor from overload or reduced
voltage conditions.

The wiring diagram attached to the product provides
required electrical information. Check that power source
is correct to properly operate the dual-voltage motor.

OPERATION

WARNING

Injury Hazard

Product surfaces become very hot during operation,
allow product surfaces to cool before handling.

Air stream from product may contain solid or liquid
material that can result in eye or skin damage,
wear proper eye protection.

Failure to follow these instructions can result in
burns, eye injury or other serious injury.

It is your responsibility to operate this product at
recommended pressures or vacuum duties and
room ambient temperatures.

Model numbers ending in "X" have automatic
thermal protectors which protect the motor by
shutting the motor off if it overheats. The motor will
automatically restart once the motor has cooled.

Start Up

If motor fails to start or slows down significantly under
load, shut off and disconnect from power supply. Check
that the voltage is correct for motor and that motor is
turning in the proper direction. Vane life will be
drastically reduced if motor is not operating properly.
Vaness can break or be damaged if motor/pump runs in
the wrong direction.

MAINTENANCE

WARNING



Electrical Shock Hazard

Disconnect electrical power supply cord before performing maintenance on this product.
If product is hard wired into system, disconnect electrical power at the circuit breaker or fuse box before performing maintenance on this product.
Failure to follow these instructions can result in death, fire or electrical shock.

WARNING

Injury Hazard

Product surfaces become very hot during operation, allow product surfaces to cool before handling.
Air stream from product may contain solid or liquid material that can result in eye or skin damage, wear proper eye protection.
Flush this product in a well ventilated area.
Failure to follow these instructions can result in burns, eye injury or other serious injury.

It is your responsibility to:

- Regularly inspect and make necessary repairs to product in order to maintain proper operation.
- Make sure that pressure and vacuum is released from product before starting maintenance.

Check intake and exhaust filters after first 500 hours of operation. Clean filters and determine how frequently filters should be checked during future operation. This one procedure will help to assure the product's performance and service life.

General Maintenance

1. Remove end cap and filters. Inspect filters for rips, tears, cuts, brittleness and excessive foreign material.
2. Clean filters if in good condition with compressed air. Re-inspect for wear conditions. Set filters aside.
3. Check filter/muffler (#11) for compacted debris. If debris is present, replace filter/muffler.
4. Check condition of O-ring. It should be soft and flexible. Replace if it is not.
5. Remove and inspect muffler box. Clean box. Set box aside. (Not all models have a muffler box.)
6. Check gasket for cracks or tears. Install new gasket if any cracks or tears appear. Replace gasket.
7. Replace muffler box.
8. Reinstall filters or install new filters if required. Reinstall end cap.

Flushing

Flushing this product to remove excessive dirt, foreign particles, moisture or oil that occurs in the operating environment will help to maintain proper vane performance. There are 2 options for this operation. If Option 1 does not remedy your problem, go on to Option 2.

Use only Gast AH255B Flushing Solvent or other non-petroleum based flushing solvent. Do Not use kerosene or ANY other combustible solvents to flush product.

Option 1

- You will need 2 pipe nipples at least 4 inches long with 1/4" NPT for 0323 and 0523 products, or 3/8" NPT on one end for 0823 and 1023 products. No nipples are needed if the unit does not have a muffler box.
1. Remove filter and muffler cap (#9).
 2. Remove 5 bolts. Use a small hammer to tap on muffler box to remove it. Attach pipe nipples where muffler caps were removed.
 3. Start product and add flushing solvent to the inlet port. If using liquid solvent, pour several tablespoons directly into the inlet port. If using Gast AH255B, spray solvent for 5-10 seconds into inlet port. Place towel over exhaust port to clean up solvent.
 4. Plug inlet port for 20-30 seconds. Listen for changes in the sound of the pump. If pump sounds smooth, go to next step. If pump does not sound like it is running smoothly, installing a Service Kit will be required (See Service).
 5. Release vacuum.
 6. Repeat steps 3-5 three or four times.

If Option 1 is not successful, remove the end plate and examine.

Option 2

1. Remove six end plate bolts. (See exploded view.)
2. Use a small hammer to carefully tap on end plate to remove. Do not use a screwdriver to pry off.
3. Check that vanes are moving freely in and out of vane slots. Replace vanes if more than 50% of the vane extends past the vane slot.
4. Remove vanes and clean both sides with fine emery cloth. Clean end-plate with fine emery cloth.
5. Flush vanes with AH255B solvent and remove all solvent from vanes.
6. Flush body, rotor and end plate with AH255B solvent, then remove all solvent from each part.
7. Check body, rotor and end plate for scoring. If each part is clean and shows no signs of scoring, re-install parts. If scoring appears, send unit to factory or replace with new part(s).

Check that all external accessories such as relief valves and gauges are attached to cover and are not damaged before re-operating product.

SHUTDOWN PROCEDURES

It is your responsibility to follow proper shutdown procedures to prevent product damage.
NEVER ADD OIL TO THIS OIL-LESS PUMP.

1. Disconnect plumbing.
2. Operate product for at least five minutes without plumbing.
3. Run at maximum vacuum for 10-15 minutes.
4. Repeat step 2.
5. Disconnect power supply.
6. Plug open ports to prevent dirt or other contaminants from entering product.

SERVICE KIT INSTALLATION

WARNING



Electrical Shock Hazard

Disconnect electrical power supply cord before installing Service Kit.

If product is hard wired into system, disconnect electrical power at the circuit breaker or fuse box before installing Service Kit.

Vent all air lines to release pressure or vacuum.

Failure to follow these instructions can result in death, fire or electrical shock.

Gast will NOT guarantee field-rebuilt product performance. For performance guarantee, the product must be returned to a Gast-authorized facility.

Service Kit contents vary. Most contain vanes, gaskets and filter parts.

1. Remove filter/muffler parts from front of muffler box.
2. Remove the 5 muffler box bolts.
3. Use a small hammer to tap on box to remove. Do not use a screwdriver.
4. Remove the 6 end plate bolts.
5. Remove end plate. Check direction of bevel edges of vanes then remove vanes.
6. Clean body and rotor slots.
7. Check end plate, rotor and body for scoring. Severe scoring or worn bearings will require service at a Gast-authorized facility.

DO NOT remove rotor or motor bolts.

8. Insert vanes, checking that the bevel edges are in the correct direction.

9. Replace end plate. Torque bolts to 90-120 in. lb.
10. Check gasket for damage.
11. Reinstall muffler box. Torque bolts to 90-120 in. lb.

Check that all external accessories such as relief valves and gauges are attached and are not damaged before re-operating product.

EXPLODED PRODUCT VIEW, PARTS & ORDERING INFORMATION

REF	DESCRIPTION	QTY	0323-101	0323-101Q	0523-101	0523-101Q	0523-V103
1	BODY	1	AK503	AK503	AK505	AK505	AK505
2*	VANE	4	AH500A	AH500A	AH500A	AH500A	AH500A
3	SHROUD	1	AK502	AK502	AK502	AK502	AK502
4	END PLATE	1	AK516A	AK501	AK516A	AK501	AK516A
5*	GASKET	1		AK521		AK521	
6	MUFFLER BOX	1		AK519		AK519	
7*	O-RING	2		AK473		AK473	
8*	FELT	2		AK524		AK524	
9	END CAP	2		AK510		AK510	
10	END CAP ASSEMBLY	2		AK526		AK526	
11	FILTER / MUFFLER	1		AK540A		AK540A	
12	FOOT SUPPORT	1		AC136		AC136	
13	ELBOW**	2				AD997	
14	MUFFLER ASSEMBLY	1				V425L	
15	JAR	2				AA125A	
16	COVER	1				AV427	
17	FELT FILTER	4				B344A	
18	SUPPORT	1				B345A	
19	COVER GASKET	2				B62A	
20	FILTER ASSEMBLY	1				V400G	
21	COVER	1				AV402CPC	
22	FILTER ASSEMBLY	1				B343B	
23	SCREEN CAP	1				AJ571	
24	FELT SUPPORT	1				B347	
	SERVICE KIT	1	K476A	K478	K478A	K478	**

* Denotes parts included in the Service Kit. Parts listed are for stock models.

** No Service Kit available, order parts separately. *** Not shown.

For specific OEM models, please consult the factory.

When corresponding or ordering parts, please give complete model and serial numbers.

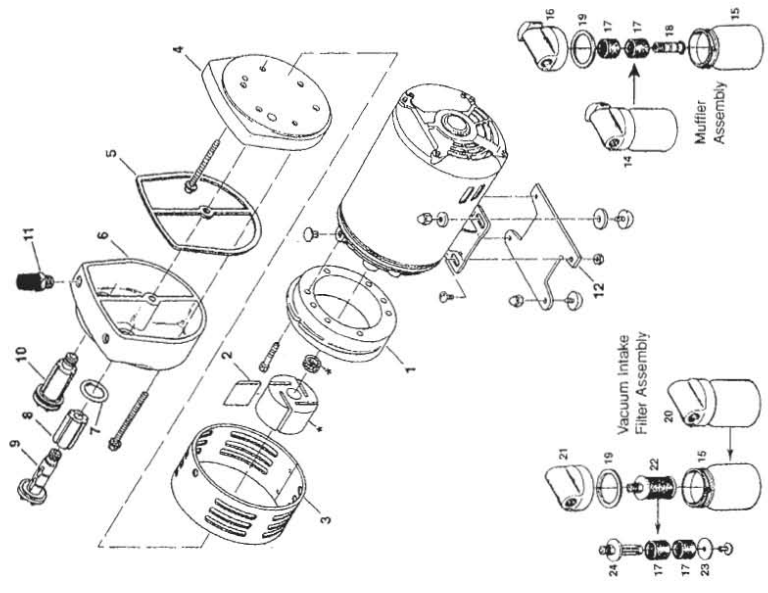

EXPLODED PRODUCT VIEW, PARTS & ORDERING INFORMATION

REF	DESCRIPTION	QTY	0823-101	1023-101	1023-101Q	1023-V103	1423-101	1423-101Q
1	BODY	1	AK517	AK518	AK518	AK518	AL283	AL283
2*	VANE	4	AK513	AK513	AK513	AK513	AL284	AL284
3	SHROUD	1	AK511	AK511	AK511	AK511	AL281	AL281
4	END PLATE	1	AK515A	AK514	AK515A	AK515A	AK514	AK514
5*	GASKET	1	AK522	AK522	AK522	AK522	AK522	AK522
6	MUFFLER BOX	1	AK520	AK520	AK520	AK520	AK520	AK520
7*	O-RING	2	AK473	AK473	AK473	AK473	AK473	AK473
8*	FELT	2	AK524	AK524	AK524	AK524	AK524	AK524
9	END CAP	2	AK510	AK510	AK510	AK510	AK510	AK510
10	END CAP ASSEMBLY	2	AK526	AK526	AK526	AK526	AK526	AK526
11	FILTER / MUFFLER	1	AK640	AK640	AK640	AD432	AC432	AC432
12	ELBOW	1				BA206	BA206	BA206
12	ELBOW ***	2			AF272			
13	MUFFLER ASSEMBLY	1			AB599B			
13a	NIPPLE	2				BA714	BA714	BA714
14	JAR	2			AA605			
15	COVER GASKET	2			AA405			
16	COVER ASSEMBLY	1			AV905BPC			
17	MUFFLER ASSEMBLY	1			AC43A-1			
18	COUPLING	2			AC391			
19	CARTRIDGE	2			AC395			
20	END CAP ASSEMBLY	2			AC384			
21	MUFFLER PLATE	1			AC395			
22	STUD	2			AC396			
23	FILTER ASSEMBLY	1			AB599			
24	COVER ASSEMBLY	1			AV905APC			
25	FILTER ASSEMBLY	1			AC433-1			
	SERVICE KIT	1	K479A	K479	K479A	K479	K575A	K575A

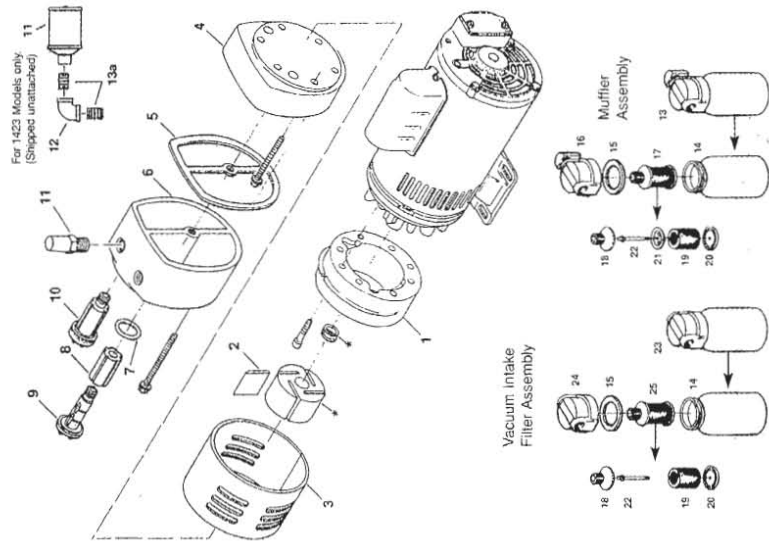

* Denotes parts included in the Service Kit. Parts listed are for stock models.
 ** No Service Kit available; order parts separately. *** Not shown.
 For specific OEM models, please consult the factory. When corresponding or ordering parts, please give complete model and serial numbers.

PART NO. 70 - 290 G375PL (REV-H)

TROUBLESHOOTING CHART

Low		High		Pump Overheat	Motor Overload	Reason and remedy for problem.
Vacuum	Pressure	Vacuum	Pressure			
●	●	At pump		●	●	Filter dirty. Clean or replace.
	●		At pump	●	●	Muffler dirty. Clean or replace.
●		At pump		●	●	Vacuum line collapsed. Repair or replace.
			●	●	●	Relief valve set too high. Inspect and adjust.
●	●					Relief valve set too low. Inspect and adjust.
●	●	At pump	At pump	●	●	Plugged vacuum/pressure line. Inspect and repair.
●	●					Vanes sticking. Clean or replace.
●	●					Vanes worn. Replace.
●	●					Shaft seal worn. Replace.
●	●			●	●	Dust or offset powder in pump. Inspect and clean.
●	●			●	●	Motor not wired correctly. Check wiring diagram and line voltage.

Product Specifications



Model Number	Motor Voltage	RPM		HP	kW	Net Wt.		"A" DIM.	"B" DIM.
		60 cycle	50 cycle			lbs.	kg.		
0523-1010-G21DX	220-250	N/A	1425	25	0.18	32	14.5	338 13.31	N/A
0523-1010-G314DX	230	1725	N/A	25	0.18	32	14.5	327 12.88	N/A
0523-5400-G21DX	220-250	N/A	1425	25	0.18	32	14.5	338 13.31	N/A
0523-5400-G314DX	230	1725	N/A	25	0.18	32	14.5	327 12.88	N/A
0523-1010-G582DX	100-115/ 100-110	1725	1425	33	0.25	30	13.6	336 13.22	N/A
0523-1010-G627DAX	220	1725	1425	25	0.18	34	15.7	339 13.36	198 7.80
0523-5360-G582DX 0523-1060-G582DX 0523-1020-G582DX	100-115/ 100-110	1725	1425	33	0.25	30	13.6	336 13.22	N/A
0523-1020-G588DX 0523-1020-SG588DX 0523-1060-G588DX	100-110/220-240 115/230	1725	1425	33	0.25	30	13.6	340 13.38	N/A
0523-5400-G588DX	100-110/220-240 115/230	1725	1425	33	0.25	30	13.6	340 13.38	N/A

PART NO:
STD210

REVISION:
J
JWA
4-1-89

SOUND LEVEL LESS THAN 70 dB(A)
 NORMAL AMBIENT 1°C - 40°C.
 RELATIVE HUMIDITY 8% - 100% NON CONDENSING
 ENVIRONMENT CLEAN DUST FREE

TECHNICAL DATA SUBJECT TO CHANGE WITHOUT NOTICE.
 SOLID LINE INDICATES 60 Hz. PERFORMANCE
 DASHED LINE INDICATES 50 Hz. PERFORMANCE
 MUFFLER IS SHIPPED ATTACHED FOR 0523-5400-G588DX.

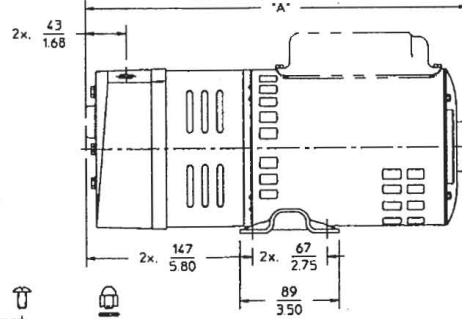
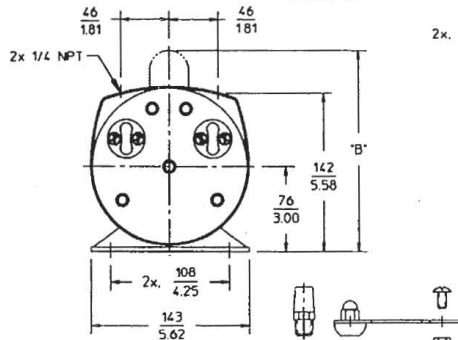
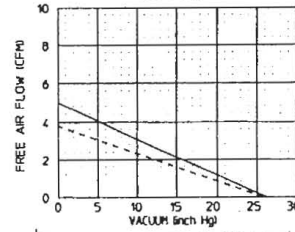
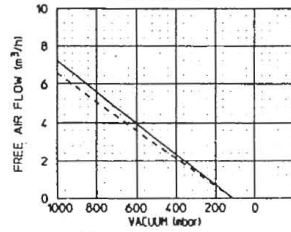
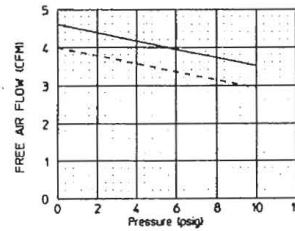
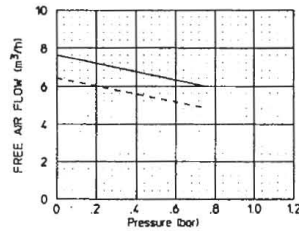

MUFFLER & FOOT SUPPORT ASM (SHIPPED UNATTACHED)

NOTE: FOOT SUPPORT ASM NOT SUPPLIED WITH 0523-5400-G21DX, -5400-G314DX, -5400-G588DX MODELS
 NOTE: FOOT SUPPORT ASM SUPPLIED ATTACHED TO MODEL 0523-5360-G582DX

ROTARY VANE - NON LUBRICATED UK10110 02/01

OPERATIONAL INSTRUCTIONS 1531, 1532, 3032, 3033, 1023, 1023, 1423, ROVA3

-ENGLISH -
(ORIGINAL INSTRUCTIONS)

Read these instructions carefully before you attempt to use this product. Only qualified engineers/electricians should undertake the installation and commissioning of this product.

USE OF PRODUCT

- * Wear eye protectors.
- * This product must only be used for the purpose of pumping/evacuating air.
- * Do not pump or evacuate any other gases or liquids.
- * The performance of the product will be adversely affected at high altitudes.
- * This product must be protected from inclement weather. It is not suitable for exterior use.
- * Do not stay in line with the air stream.
- * Do not try to obtain higher pressures or vacuums than those recommended. Refer to technical data sheet supplied.
- * Damage will occur if the product is driven at higher speeds than those recommended. Refer to technical data sheet supplied.

INSTALLATION

- * Refer to the technical sheet supplied for full technical specification.
- * Only qualified electricians should undertake the wiring of the electric motor.
- * The wiring of the electric motor should be made in accordance with local electrical regulations.
- * Ensure that the product ventilation grilles are kept free from obstruction.
- * Do not place any objects, fingers, metal tools etc., through the grille holes.
- * Check that the mains supply voltage is correct for the product - see nameplate. Contact the factory immediately if the voltage conditions are different.
- * Remove the plastic port plugs, retain if you are likely to decommission and store the product in the future - see shutdown and storage.
- * Do not touch the product during and just after operation as all parts of the product get very hot.
- * Supply and install a check valve, minimum 30 cm from port to prevent back pressure.
- * Do not fumigate any part of this product.
- * Do not install with pipes that are smaller than the size of the head ports.
- * Do not use thread tapes to seal pipe threads.
- * Use only the correct pipe size on the thread.
- * Fit a recommended filter/muffler to the inlet/exhaust port.
- * For pressure applications always fit a relief valve set to the maximum pressure allowed but never higher than the maximum permitted pressure specified on the technical data sheet.
- * For vacuum applications it is recommended a relief

MAINTENANCE & SERVICE

- * Switch the electricity supply "OFF" and isolate the product.
- * Vent all pressure/vacuum from the product.
- * Replace inlet filter/exhaust muffler elements and filters when necessary.
- * Filters will become blocked quickly in dirty environments. Establish service periods by checking condition after 200 hours.
- * Connect electricity supply and switch "ON".
- * The product will start immediately.

Service kits are available, follow the instructions supplied with the kit. Should the product require more than a maintenance service it is recommended you contact the manufacturer or authorised distributor.

GAST WARRANTY

Gast finished products, when properly installed and operated under normal conditions of use, are warranted by Gast to be free from defects in material and workmanship for a period of twelve (12) months from the date of purchase from Gast or an authorised Gast Representative or Distributor. In order to obtain performance under this warranty, the buyer must promptly (in no event later than thirty days) notify Gast in writing of any defect, give written notice to defect. Gast Manufacturers' Centres are: Gast Ltd, Unit 10, DIXIE Corporation, Beech House, Kewes Beech Business Centre, Loudwater, High Wycombe, Bucks HP10 9SD, U.K. or an authorised Service Centre (unless specifically agreed upon in writing signed by both parties or specified in writing as part of a Gast O&M Quotation).

Buyer is responsible for freight charges both to and from Gast in all cases. This warranty does not apply to electric motors, electrical controls and gasoline engines not supplied by Gast. Gast's warranties also do not extend to any goods or parts which have been subjected to misuse, lack of maintenance, neglect, damage by accident or transit damage.

THIS EXPRESS WARRANTY EXCLUDES ALL OTHER WARRANTIES OR REPRESENTATIONS EXPRESSED OR IMPLIED BY ANY LITERATURE, DATE OR PERSON. GAST'S MAXIMUM LIABILITY UNDER THIS EXCLUSIVE REMEDY SHALL NEVER EXCEED THE COST OF THE

TROUBLE SHOOTING GUIDE

Possible Reasons	Low Vacuum	Low Pressure	High Vacuum	High Pressure	Over Heating	Motor Overload
Dirty Filter	X	X			X	X
Dirty Muffler		X			X	X
Vacuum Line Collapsed	X				X	X
Relief Valve Set Too High			X	X		
Relief Valve Set Too Low	X	X			X	X
Blocked Vacuum/Pressure Line	X	X			X	X
Sticking Vanes						
RPM Too High		X	X	X		X
Worn Vanes	X	X			X	X
Dirt in Body	X	X			X	X
Not Wired Correctly	X	X			X	X

SUBJECT PRODUCT AND GAST RESERVES THE RIGHT ITS SOLE DISCRETION, TO REFUND THE PURCHASE PRICE IN LIEU OF REPAIR OR REPLACEMENT.

GAST WILL NOT BE RESPONSIBLE OR LIABLE INDIRECT OR CONSEQUENTIAL DAMAGES OF ANY KIND, INCLUDING BUT NOT LIMITED TO those for use of the product in applications where the manufacturer has not intended or consequential damages with respect to business or property, whether as a result of breach of warranty or otherwise. Notwithstanding any other provision this warranty, BUYER'S REMEDY AGAINST GAST GOODS SUPPLIED OR FOR NON-DELIVERED GOODS FAILURE TO FURNISH GOODS, WHETHER OR NOT BA EXPRESS OR IMPLIED WARRANTY IS LIMITED TO THE PRICE AT GAST'S OPTION TO REPLACEMENT OF OR CURE SUCH NON-CONFORMING OR NON-DELIVERED GOODS RETURN OF THE PURCHASE PRICE FOR SUCH GOOD AND IN NO EVENT SHALL EXCEED THE PRICE CHARGE FOR SUCH GOODS.

GAST EXPRESSLY DISCLAIMS ANY WARRANTY OF MERCHANTABILITY OR FITNESS FOR GOODS TO BE USED FOR PURPOSES WITH RESPECT TO WHICH GAST HAS MADE NO WARRANTIES WHICH EXTEND BEYOND THE DESCRIPTIONS SET FORTH IN THIS WARRANTY. Notwithstanding any knowledge of Gast regarding the use or intended to be made of goods, proposed changes or addition goods, or any assistance or suggestions that may have been made by Gast personnel.

Unauthorised extensions of warranties by the customer shall not be the customer's responsibility.

CUSTOMER IS RESPONSIBLE FOR DETERMINING THE SUITABILITY OF GAST PRODUCTS FOR CUSTOMER'S USE OR RESALE, OR FOR INCORPORATING THEM IN OBJECTS OR APPLICATIONS WHICH CUSTOMER DESIGN ASSEMBLES, CONSTRUCTS OR MANUFACTURES.

This warranty can be modified only by authorised Gast personnel signing a specific, written description of any modifications.

Effective 01/0

RATEMASTER® FLOWMETER

Installation and Operating Instructions

DIMENSIONS & MOUNTING INFORMATION

DIMENSIONS - IN INCHES			
	RMA	RMB	RMC
A	4 3/16"	8-1/2"	15-1/8"
B	3"	6-7/16"	12-1/4"
C	1/8" NPT CONN. 1-5/8"	1/4" NPT CONN. 1-15/16"	1/2" NPT CONN. 1-3/4"
D	10-32 THDS.	1/4-20 THDS.	3/8-24 THDS.
E	3/8"	5/8"	1"
F	1-1/16"	1-7/8"	2-3/4"
G	1-3/16"	1-3/4"	2-1/4"
H	11/16"	1"	1-7/16"
I (DPEH)	1"	1-7/16"	1-31/32"
J	13/8"	1 11/16"	2 1/2"
K	3/4"	1-1/4"	2"
L	4-13/16"	8-3/4"	15-3/8"
	1"	1-1/2"	2-1/4"

PANEL CUT OUT (FOR FLUSH MOUNTING)

HIGH	4-5/8"	8-3/16"	15-3/16"
WIDE	7/8"	1-5/16"	2-1/16"

PANEL HOLE SIZES (FOR SURFACE MOUNTING)

PIPE	7/16"	5/8"	15/16"
BOLT	1/4"	3/32"	13/32"

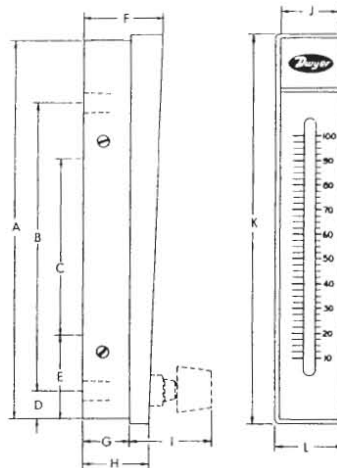

Figure 1

Dwyer Rate-Master® Series RM Flowmeters are furnished in three models (see Figure 1) each available in a broad choice of flow ranges with direct reading scales for air, gas or water. Installation, operation and maintenance are very simple and only a few common sense precautions must be observed to assure long, trouble-free service.

CAUTION

Dwyer Rate-Master(R) flowmeters are designed to provide satisfactory long term service when used with air, water or other compatible media. Refer to factory for information on questionable gases or liquids. Avoid solutions of acids, bases or salts having a pH below 5.0 or above 8.5. Caustic solutions, anti-freeze (ethylene glycol) and aromatic solvents should definitely not be used.

CALIBRATION

Each Dwyer flowmeter is calibrated at the factory. If at any time during the meter's life, you wish to recheck its calibration, do so only with devices of certified accuracy. DO NOT attempt to check the Dwyer Rate-Master® Flowmeter with a similar flowmeter as seemingly unimportant variations in piping and back pressure may cause noticeable differences in the indicated reading. If in doubt, return your Dwyer flowmeter to the factory. It will be calibration checked for you at no charge. Before proceeding with the installation of your Dwyer Rate-Master Flowmeter, check to be sure you have the model and flow range you require.

LOCATION

TEMPERATURE, PRESSURE, ATMOSPHERE, AND VIBRATION: Rate-Master Polycarbonate Flowmeters are exceptionally tough and strong. They are designed for use at pressures up to 100 PSI (RMB units 70 PSI, RMC 35 PSI) and temperatures up to 130 deg. F. **DO NOT EXCEED THESE LIMITS!** The installation should not be exposed to strong chlorine atmospheres or solvents such as benzene, acetone, carbon tetrachloride, etc. The mounting panel should be free of excessive

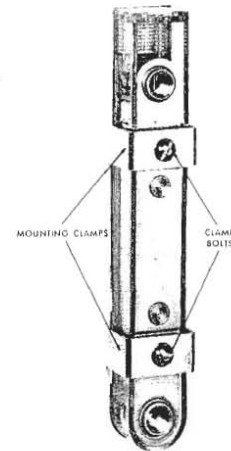

Figure 2

INLET PIPING RUN: It is good practice to approach the flowmeter inlet with as few elbows and restrictions as possible. In every case the inlet piping should be at least as large as the connection to the flowmeter i.e. 1/8" Iron Pipe Size for RMA, 1/4" IPS for RMB and 1/2" IPS for RMC. Length of inlet piping makes little difference for normal pressure fed flowmeters.

For flowmeters on vacuum air service the inlet piping should be as short and open as possible. This will allow operation near atmospheric pressure and thereby insure the accuracy of the device. (Note that for vacuum air service the flow control valve if any, should be on the discharge side of the flowmeter. Either the TMV unit or a separate in line valve may be applied.)

DISCHARGE PIPING: As on the inlet, discharge piping should be at least as large as the flowmeter connection. In addition, for pressure fed flowmeters on air or gas service the discharge piping should be as short and open as possible. This will allow operation of the flow tube at near atmospheric pressure and insure the accuracy of the device. This is of less importance on water or liquid flowmeters since the flowing medium is generally incompressible and moderate back pressure will not affect the accuracy of the instrument as calibrated.

POSITION AND MOUNTING

All Rate-Master Flowmeters must be mounted in a vertical position with the inlet connection at the bottom rear and outlet at top rear.

BEZEL OR THROUGH PANEL MOUNTING: Make the panel cutout using the appropriate dimensions from Figure 1. Flowmeter must fit into the panel freely without force or squeeze.

Insert the Rate-Master Flowmeter from the front of the panel and install the mounting clamps from the rear, insert and tighten the clamp bolts in the locations shown in Figure 2. Do not exceed 5 in./lbs. Make connections to inlet and outlet ports using small amount of RTV sealant or Teflon® thread tape to avoid leakage.

RATEMASTER® FLOWMETER

Instructions

BULLETIN F-43
PAGE 2

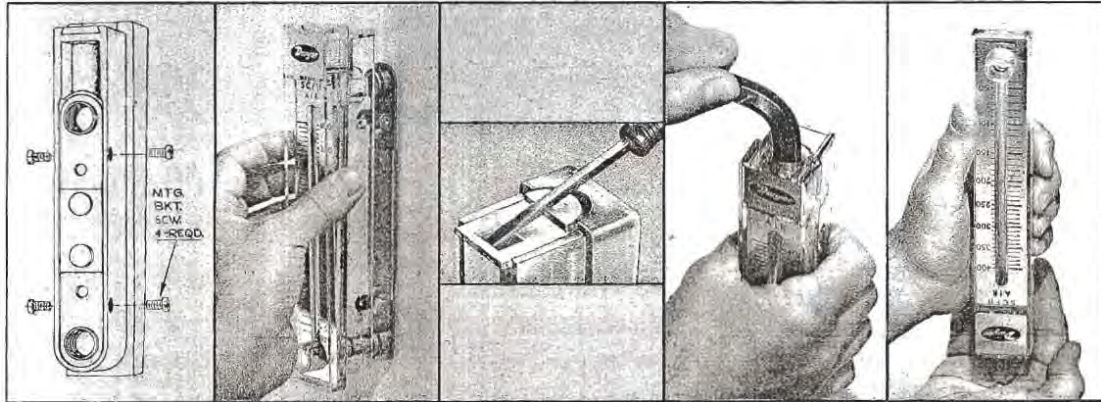

Figure 3

Figure 4

Figure 5

Figure 6

Figure 7

SURFACE MOUNTING: Drill appropriate holes in panel using the dimensions shown in Figure 1. Hold the flowmeter in position in front of the panel and install the clamp bolts through the panel from the rear. (The mounting clamps may be used as washers if desired by installing them backwards or straightening them out.) Pipe up inlet and discharge following the directions in previous sections.

SURFACE MOUNTING ON PIPING ONLY: An alternate method of surface mounting omitting the clamp bolts and supporting the Rate-Master Flowmeter on the connecting piping only is possible. For this method extra long or straight pipe threads should be used so that nuts may be run onto the pipe and later tightened against the back of the panel to retain the unit in proper position. Use the appropriate hole layout information from Figure 1, but omit the small holes.

MOUNTING ON PIPING ONLY WITHOUT PANEL: For a temporary or laboratory type installation, the panel may be omitted altogether and the flowmeter installed directly in rigid piping. Its light weight permits this without difficulty.

OPERATION

To start system, open the valve slowly to avoid possible damage. Rate of flow is read at the point of maximum horizontal width for spherical floats or at the top of the largest diameter for non-spherical floats. Control valves on BV and SSV models are turned clockwise to reduce flow, counter clockwise to increase flow. A nylon insert is provided in the threaded section of the valve stem to give a firm touch to the valve and to prevent change of setting due to vibration.

CAUTION

Do not completely unscrew valve stem unless flowmeter is unpressurized and drained of any liquid. Removal while in service will allow gas or liquid to flow out front of valve body and could result in serious personal injury. For applications involving high pressure and/or toxic gasses or fluids, special non-removable valves are available on special order. Contact factory for details.

MAINTENANCE

The only maintenance normally required is occasional cleaning to assure reliable operation and good float visibility.

DISASSEMBLY: The flowmeter can be disassembled for cleaning simply as follows:

1. Remove valve knob from RMB or RMC — BV or SSV units by pulling the knob forward. It is retained by spring pressure on the stem half-shaft so that a gentle pull will remove it. On RMA-BV or SSV models, turn the valve knob counter-clockwise until the threads are disengaged. Then withdraw the stem from the valve by gently pulling on the knob.
2. Remove the four mounting bracket screws located in the sides of the flowmeter. See Figure 3.

Pull the flowmeter body gently forward away from the back plate and pipe thread connections. Keep the body parallel with the back plate to avoid undue strain on the body. Leave the piping connections intact. There is no need to disturb them. See Figure 4.

3. Remove the slip cap with a push on a screwdriver as shown in Figure 5. Remove the plug-ball stop as shown in Figure 6 using allen wrench sizes as follows: Model RMA — 1/4", Model RMB — 1/2", and Model RMC — 3/4".

4. Take out the ball or float by inverting the body and allowing the float to fall into your hand as shown in Figure 7. (Note: It is best to cover the discharge port to avoid losing the float through that opening.)

CLEANING: The flow tube and flowmeter body can best be cleaned with a little pure soap and water. Use of a bottle brush or other soft brush will aid the cleaning. Avoid benzene, acetone, carbon tetrachloride, alkaline detergents, caustic soda, liquid soaps (which may contain chlorinated solvents), etc. and avoid prolonged immersion which may harm or loosen the scale.

REASSEMBLY: Simply reverse Steps 5A, 1 through 4 and place back in service. A little stop cock grease or petroleum jelly on the "O" rings will help maintain a good seal as well as facilitate assembly. No other special care is required.

ADDITIONAL INFORMATION

For additional flowmeter application information, conversion curves, factors and other data covering the entire line of Dwyer Rate-Master Flowmeters, send for Bulletin F-41.

MODEL CUB3T3 & CUB3T4 - GENERAL PURPOSE MINIATURE ELECTRONIC TIMERS



- 6-DIGIT TIMER ACCUMULATES TIME IN HOURS, 1/10 HOURS, 1/100 HOURS, OR 1/10 MINUTES
- OPERATES FROM EITHER SWITCH CONTACT, OR 10 to 300 V (AC 50/60 Hz or DC) INPUTS
- SELF-POWERED WITH INTERNAL LITHIUM BATTERY FOR UP TO 7 YEARS OF CONTINUOUS OPERATION
- AVAILABLE IN FRONT PANEL AND REMOTE RESET OR REMOTE RESET ONLY MODELS
- EASY SNAP-IN MOUNTING IN 1" X 2" (25 mm x 50 mm) PANEL OPENING
- IDEAL FOR PORTABLE, MOBILE, OR STATIONARY INDUSTRIAL EQUIPMENT

DESCRIPTION

The CUB3T's are state-of-the-art products with Micro-Electronic technology. They open up a wide variety of new timing application possibilities that, until now, were economically impractical.

The CUB3T3 and CUB3T4 are designed to be used as hour, tenth hour, hundredth hour or tenth minute timers. The timing function on both models can be actuated by either a contact closure or the application of 10 to 300 (AC 50/60 Hz or DC). Both models are equipped with a remote reset. The CUB3T4 has the additional feature of a front panel reset. Time is displayed on a 6 digit LCD that will wrap around from a full display of "999999" to "000000" when an overflow occurs. An indicator, located in the upper left-hand corner of the display, will blink at 2 Hz whenever the timer is actuated. The front panel reset feature of the CUB3T4 allows the user to periodically measure elapsed time. The CUB3T3, on the other hand, is ideally suited for measuring total run time.

Application of the CUB3T is simplicity itself. Its rugged reinforced nylon case snap-fits into a standard rectangular opening without screws or other hardware. No external power source is required since the internal lithium battery provides up to 7 years of uninterrupted service. In addition to these advantages, the CUB3T offers integrated circuitry, embedded in a single monolithic, silicon micro-chip.

SAFETY SUMMARY

All safety related regulations, local codes and instructions that appear in this bulletin or on equipment must be observed to ensure personal safety and to prevent damage to either the instrument or equipment connected to it. If equipment is used in a manner not specified by the manufacturer, the protection provided by the equipment may be impaired.

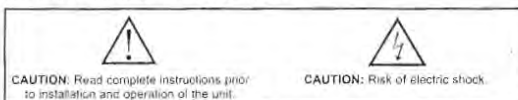

 Metal panel must be connected to protective earth ground.

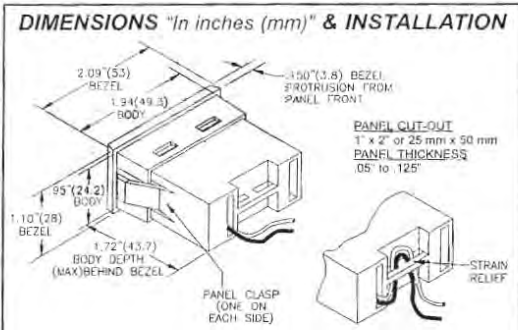

SPECIFICATIONS

1. **DISPLAY:** 6-Digit, LCD, 0.2" (5.1 mm) High
2. **POWER:** 3 Volts supplied by a non-replaceable lithium battery. Nominal battery life is 7 years. Battery life is dependent upon usage. Signal and reset contacts that remain closed for long periods of time reduce battery life.
3. **REMOTE RESET:**
50 msec min. pulse width (active low) from 3.0 V bi-polar output, an open collector transistor, or a switch contact to common.
 $V_{IH} = 2.0$ V min. (3 V max), $V_{IL} = 0.5$ V max.
4. **SIGNAL INPUT:**
Contact Connections: Switch Contact or Solid-State Transistor Switch. Contact burden 15 jumps max. A maintained closed switch will actuate the timer.
10 to 300 V Connections: 10 V min. to 300 V max. (AC 50/60 Hz or DC). Input current 0.5 mA max. Constant voltage applied to the inputs will actuate the timer.
5. **CERTIFICATIONS AND COMPLIANCES:**

SAFETY

EN 61010-1, IEC 1010-1

Safety requirements for electrical equipment for measurement, control, and laboratory use, Part I.

ELECTROMAGNETIC COMPATIBILITY

Immunity to EN 50082-2

Electrostatic discharge	EN 61000-4-2	Level 2; 4 Kv contact ¹ Level 3; 8 Kv air
Electromagnetic RF fields	EN 61000-4-3	Level 3; 10 V/m 80 MHz - 1 GHz
Fast transients (burst)	EN 61000-4-4	Level 4; 2 Kv I/O ²
RF conducted interference	EN 61000-4-6	Level 3; 10 Vrms 150 KHz - 80 MHz

Emissions to EN 50081-1

RF interference	EN 55022	Enclosure class B
-----------------	----------	-------------------

Notes:

1. For operation without loss of performance in static environments above 4 KV, typical anti-static precautions should be observed before touching the bezel.
2. For operation without loss of performance install 1 ferrite core, RLCHFCOR0000 or equivalent, to cables at unit.
OR
Route I/O cables in metal conduit connected to earth ground.

Refer to the EMC Installation Guidelines for additional information.

6. ENVIRONMENTAL CONDITIONS:

Operating Temperature: -25 to +75°C

Storage Temperature: -30 to 75°C

Operating and Storage Humidity: 85% max. RH (non-condensing) from -25°C to +75°C.

Altitude: Up to 2000 meters

7. CONSTRUCTION: Installation Category II, Pollution Degree 2.

8. ACCURACY: 0.025%

9. WEIGHT: 2 oz (56.7 g)

EMC INSTALLATION GUIDELINES

Although this unit is designed with a high degree of immunity to ElectroMagnetic Interference (EMI), proper installation and wiring methods must be followed to ensure compatibility in each application. The type of the electrical noise, source or coupling method into the unit may be different for various installations. Cable length, routing and shield termination are very important and can mean the difference between a successful or a troublesome installation. Listed below are some EMC guidelines for successful installation in an industrial environment.

- Use shielded (screened) cables for all Signal and Control inputs. The shield (screen) pigtail connection should be made as short as possible. The connection point for the shield depends somewhat upon the application. Listed below are the recommended methods of connecting the shield, in order of their effectiveness.
 - Connect the shield only at the panel where the unit is mounted to earth ground (protective earth).
 - Connect the shield to earth ground at both ends of the cable, usually when the noise source frequency is above 1 MHz.
- Never run Signal or Control cables in the same conduit or raceway with AC power lines, conductors feeding motors, solenoids, SCR controls, and heaters, etc. The cables should be run in metal conduit that is properly grounded. This is especially useful in applications where cable runs are long and portable two-way radios are used in close proximity or if the installation is near a commercial radio transmitter.
- Signal or Control cables within an enclosure should be routed as far away as possible from contactors, control relays, transformers, and other noisy components.
- In extremely high EMI environments, the use of external EMI suppression devices, such as ferrite suppression cores, is effective. Install them on Signal and Control cables as close to the unit as possible. Loop the cable through the core several times or use multiple cores on each cable for additional protection. The following EMI suppression devices (or equivalent) are recommended:
 - Ferrite Suppression Cores for signal and control cables:
 - Fair-Rite # 0443167251 (RLC #FCOR0000)
 - TDK # ZCAT3035-1330A
 - Steward #28B2029-0A0
- Long cable runs are more susceptible to EMI pickup than short cable runs. Therefore, keep cable runs as short as possible.

TYPICAL APPLICATIONS

An equipment rental company charges customers by the hour for the rental of forklifts or other heavy equipment. To help determine the amount of actual run time, a CUB3T300 is connected to a spare set of contacts on the ignition switch of the forklift. When the switch is in the "RUN" position, the "Orn/Whit" and "White" leads of the CUB3T3 are connected, which cause it to accumulate time in hours on the display. The rental company simply resets the CUB3T3 by momentarily closing the connection between the "Orn/Whit" and "Blue" leads before each rental period. The normally open "REMOTE RESET" push-button (installed by the rental company) is protected to prevent tampering by the customer.

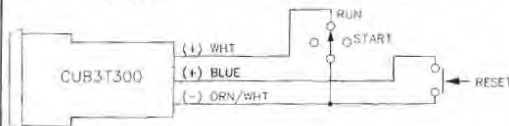

A machine shop manager charges customers for machine time by the hour. He is also interested in tracking machine run time vs. down time. A CUB3T310 connected across the 115 VAC spindle motor of a drill press will serve both purposes. A reading taken before and after each job will indicate the actual machine run time in tenth hour increments. A reading at the beginning and end of each shift will indicate total run time, allowing the manager to evaluate production efficiency and down time.

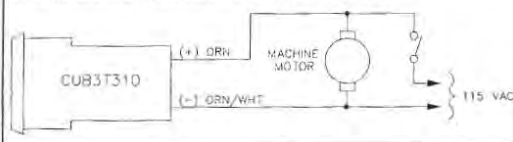

ELECTRICAL CONNECTIONS & INPUTS

All conductors should meet voltage and current ratings for each terminal. Also, cabling should conform to appropriate standards of good installation, local codes and regulations. It is recommended that voltage connections to the unit be protected by a fuse or circuit breaker.

The CUB3T's can be supplied with input signals from mechanical switch contacts or solid-state switches as shown in the diagrams below. Reed switches, mercury-wetted contacts, snap-action limit switches, and silver alloy contacts with wiping action are usually satisfactory choices for mechanical switch input. Heavy "clapper-type" contacts such as used in contactors or large machine tool relays, tungsten contacts, or brush type contacts are not recommended for the low level switching used by the input to the timer.

To avoid injury to personnel or equipment, properly isolate all unused wires. For example, wire nuts, closed end splices, or other types of wire terminators should be used.

Warning: Connecting voltage to contact or reset inputs will cause damage to the unit.

10 to 300 V Voltage Connections

Warning: Any lead may be at hazardous live input potential. External wiring and devices connected to the unit must be rated the same as applied signal input voltage and be properly isolated from Class 2 or SELV circuitry.

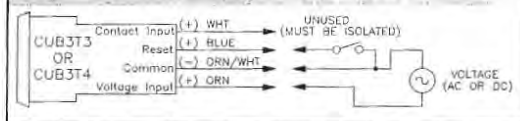

Contact Connections

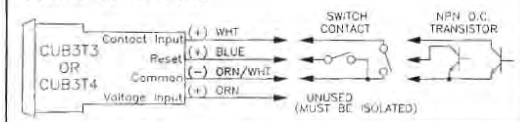

Installation Environment

The unit should be installed in a location that does not exceed the maximum operating temperature and provides good air circulation. Placing the unit near devices that generate excessive heat should be avoided.

The bezel should be cleaned only with a neutral soap product applied to a soft damp cloth. Do NOT use solvents.

Continuous exposure to direct sunlight may accelerate the aging process of the display.

Do not use tools of any kind (screwdriver, pens, pencils, etc.) to operate the reset button of this unit.

TROUBLESHOOTING

For further technical assistance, contact technical support at the appropriate company numbers.

WARNING: Lithium battery may explode if incinerated. Input voltage must not exceed 3.0 VDC on contact input or maximum rated voltage on voltage input to prevent damage to the unit.

ORDERING INFORMATION

MODEL NO.	DESCRIPTION	PART NUMBER
CUB3T3	Timer, 1 hr., Remote Reset Only	CUB3T300
	Timer, 0.1 hr., Remote Reset Only	CUB3T310
	Timer, 0.01 hr., Remote Reset Only	CUB3T320
	Timer, 0.1 min., Remote Reset Only	CUB3T330
CUB3T4	Timer, 1 hr. w/Front Panel and Remote Reset	CUB3T400
	Timer, 0.1 hr. w/Front Panel and Remote Reset	CUB3T410
	Timer, 0.01 hr. w/Front Panel and Remote Reset	CUB3T420
	Timer, 0.1 min. w/Front Panel and Remote Reset	CUB3T430

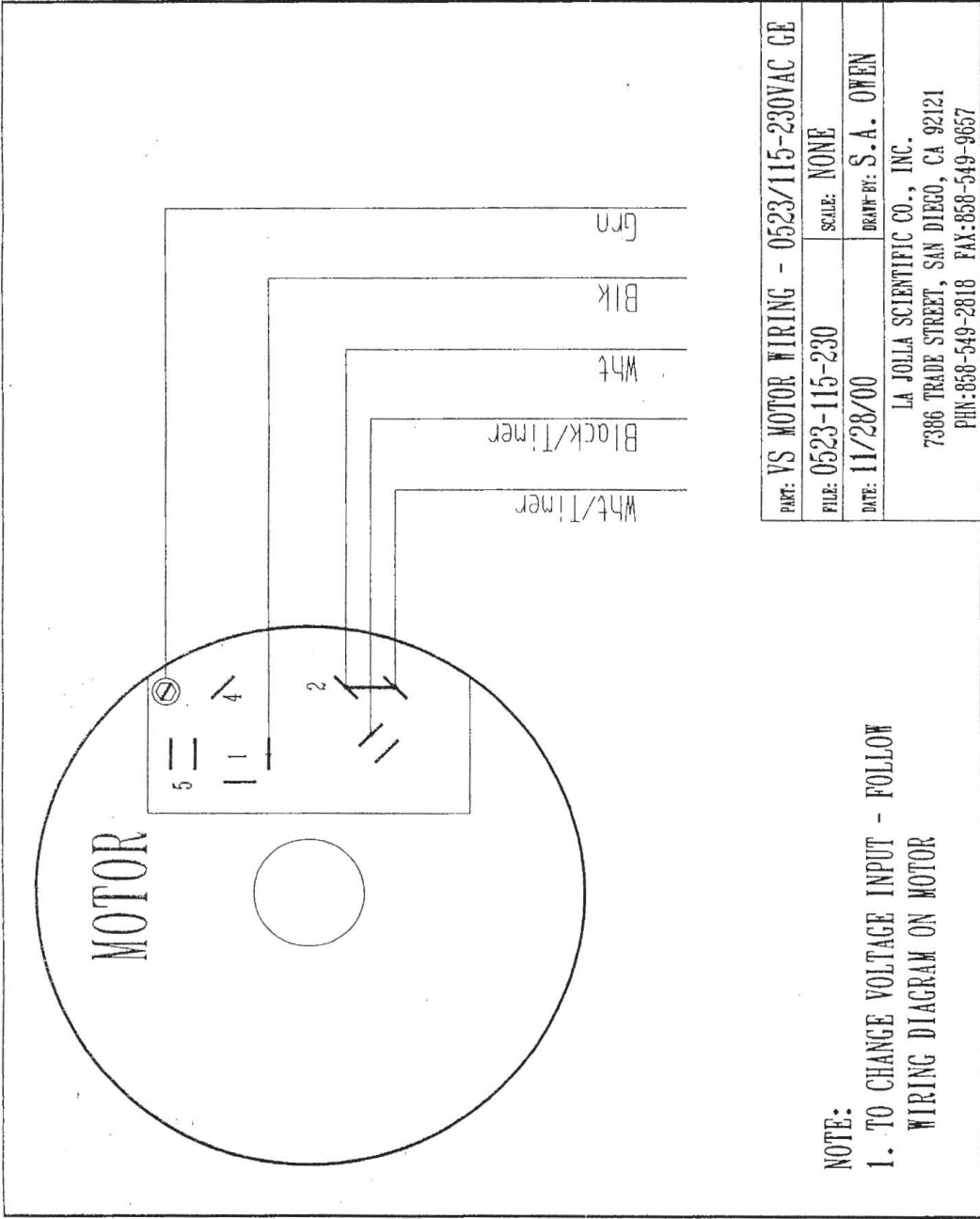

PART: VS MOTOR WIRING - 0523/115-230VAC GE
 FILE: 0523-115-230 SCALE: NONE
 DATE: 11/28/00 DRAWN BY: S. A. OWEN
 LA JOLLA SCIENTIFIC CO., INC.
 7386 TRADE STREET, SAN DIEGO, CA 92121
 PHN: 858-549-2818 FAX: 858-549-9657

**HI-Q Environmental
Products Co.**

7386 Trade Street
San Diego, California 92121-2422

Division of La Jolla Scientific Co., Inc.

Phone: (858) 549-2820
Fax: (858) 549-9657

INSTRUMENT CALIBRATION CERTIFICATION

It is certified that this instrument, identified herein has been calibrated using standards whose' calibration is traceable to the U.S. National Institute of Standards and Technology.

Item: VS23-0523CV
Serial Number: 17284
Calibrated For: S.M. STOLLER CORP
105 TECHNOLOGY DRIVE, STE 190
BROOMFIELD, CO 80021
Purchase Order: 08-1025

Certification against Meriam Laminar Flow Element (LFE) model number 50MW20-1½ , serial number 731410-D1. The LFE used to calibrate the item above has been calibrated and correlated at several points of flow rate per the calibration system requirements of ANSI Z540-1 and is traceable to the National Institute of Standards and Technology. The total rss uncertainty of the working master LFE is +/- 0.72% of the reading.

The NIST Traceability tests used for working Master are:	253699, 820312HJ, 822/MET54;MET55;MET56;MET57 731/243669, 732/246837, 731/245367, 731/242697 822/250904, 252897
--	--

The Merium LFE is calibrated with air at atmospheric conditions and referenced to 29.92" Hg (760mm Hg) absolute, at 70 °F (21.1 C). Each completed element is calibrated and correlated to read within +/- 5% of the Merium Flow standards.

Date Unit Calibrated:	01/09/08	
Barometric Pressure (actual):	29.93	" Hg
Relative Humidity (actual):	42	%
Temperature (actual):	71	°F
Calibration Filter Media):	OPEN AIR	

Certification Information:

This unit has been calibrated against the above listed primary element. The markings are made directly on the meter face. The readings therefore are direct readings for this individual unit at the temperature, relative humidity, and barometric pressure indicated at the time of calibration.

For absolute readings, a correction factor must be applied to the apparent reading, using the actual barometric pressure, and actual temperature of the ambient air being measured.

Certified by:  / Calibration Department Date: 1/9/08

Verified by:  / QA Supervisor Date: 1/9/08

HI-Q Environmental
Products Co.

7386 Trade Street
San Diego, California 92121-2422

Division of La Jolla Scientific Co., Inc.

Phone: (858) 549-2820
Fax: (858) 549-9657

HOW TO CORRECT FOR BAROMETRIC PRESSURE, ELEVATION, AND TEMPERATURES OTHER THAN STANDARD

This unit has been calibrated to directly read the apparent flow numbers when Standard Temperature and Pressure (STP) conditions prevail.

Standard temperature is: 70 degrees F, and standard pressure is: 29.92" Hg (at sea level).

When you are using this device at a barometric pressure other than 29.92" Hg, and a temperature other than 70 degrees F, a correction must be made to the apparent reading. Since elevation above sea level significantly effects the barometric pressure, elevation must be considered. For example, if the barometric pressure at sea level today is the standard 29.92" Hg, at 6,000 feet the BP will be 23.98" Hg. The correction factor for the elevation alone, (not including temperature), is a multiplier of 0.895. Therefore a unit calibrated at STP (sea level), reading 5.0 CFM apparent at 6,000 feet., will be only 4.475 SCFM corrected to STP. Temperature changes must also be compensated for if they are other than 70 degrees F, standard conditions.

Note: If the flow device will always be used at an increased elevation such as the 5,200 feet in Denver, HI-Q can calibrate your flow calibration instrument compensating for that elevation, at the time of purchase or re-calibration. We will have to know those elevations at the time of the order. You will still have to correct for barometric and temperature changes from your now " Standard " conditions.

Standard procedure for determining the true SCFM or SLPM from the apparent reading of the flow device, at conditions other than STP (29.92" and 70 Deg. F).

- 1.) Record the actual barometric pressure (BP_{actual}). This can be secured from your own Barometer, the local weather bureau, or the airport. A local reading will automatically compensate for altitude other than sea level. Read the correction multiplier "A" from the chart A-31031.
- 2.) Record the actual temperature in degrees F. Read the correction multiplier "B" from the chart A-32422.
- 3.) Multiply $A \times B = f$ (factor).
- 4.) Multiply the apparent reading from the meter flow device by the factor f. This will give you the true reading in SCFM or SLPM at your particular weather conditions.

HI-Q Environmental Table A-32422
Air Temperature/Viscosity Correction Factors for SCFM
Air Base Temperature 70 °F, Viscosity 181.87 Micropoise
 Reference NBS Circular 564

$$\text{CORRECTION FACTOR} = \sqrt{\frac{529.67}{459.67 + ^\circ\text{F}} \times \frac{181.87}{\mu\text{g}^*}}$$

$$\mu_{\text{air}} = \frac{14.58 \left(\frac{459.67 + ^\circ\text{F}}{18} \right)^{3/2}}{110.4 + \left(\frac{459.67 + ^\circ\text{F}}{18} \right)}$$

Temp °F	+0	+1	+2	+3	+4	+5	+6	+7	+8	+9
0	1.1350	1.1328	1.1306	1.1284	1.1262	1.1240	1.1219	1.1197	1.1175	1.1154
10	1.1133	1.1111	1.1090	1.1069	1.1048	1.1027	1.1006	1.0986	1.0965	1.0945
20	1.0924	1.0904	1.0883	1.0863	1.0843	1.0823	1.0803	1.0783	1.0763	1.0744
30	1.0724	1.0705	1.0685	1.0666	1.0646	1.0627	1.0608	1.0589	1.0570	1.0551
40	1.0532	1.0513	1.0495	1.0476	1.0458	1.0439	1.0421	1.0402	1.0384	1.0366
50	1.0348	1.0330	1.0312	1.0294	1.0276	1.0258	1.0241	1.0223	1.0205	1.0188
60	1.0171	1.0153	1.0136	1.0119	1.0102	1.0084	1.0067	1.0050	1.0034	1.0017
70	1.0000	0.9983	0.9967	0.9950	0.9934	0.9917	0.9901	0.9884	0.9868	0.9852
80	0.9836	0.9820	0.9804	0.9788	0.9772	0.9756	0.9740	0.9724	0.9709	0.9693
90	0.9677	0.9662	0.9646	0.9631	0.9616	0.9600	0.9585	0.9570	0.9555	0.9540
100	0.9525	0.9510	0.9495	0.9480	0.9465	0.9450	0.9436	0.9421	0.9406	0.9392
110	0.9377	0.9363	0.9349	0.9334	0.9320	0.9306	0.9291	0.9277	0.9263	0.9249
120	0.9235	0.9221	0.9207	0.9193	0.9180	0.9166	0.9152	0.9138	0.9125	0.9111
130	0.9098	0.9084	0.9071	0.9057	0.9044	0.9031	0.9017	0.9004	0.8991	0.8978
140	0.8965	0.8952	0.8939	0.8926	0.8913	0.8900	0.8887	0.8874	0.8862	0.8849
150	0.8836	0.8824	0.8811	0.8798	0.8786	0.8773	0.8761	0.8749	0.8736	0.8724

*When flowing gas other than air, use the viscosity in micropoise of the gas at flowing temperature in the Correction Factor equation.

Altitude Pressure Table
Mercury at 0°C (32°F)

Altitude in Feet	Inches of Mercury
-1,000	31.02
0	29.92
1,000	28.86
2,000	27.82
3,000	26.81
4,000	25.84
5,000	24.89
6,000	23.98
7,000	23.09
8,000	22.22
9,000	21.38
10,000	20.58

HI-Q Environmental Table A-31031
Laminar Flow Element Pressure Correction Factor (any gas)
 Base Pressure (Assigned Standard) 29.92 Inches Mercury Absolute

Laminar Inlet Pressure Hg. ABS.	P _{cf}	Laminar Inlet Pressure Hg. ABS.	P _{cf}	Laminar Inlet Pressure Hg. ABS.	P _{cf}	Laminar Inlet Pressure Hg. ABS.	P _{cf}	Laminar Inlet Pressure Hg. ABS.	P _{cf}
26.00	0.8690	28.00	0.9358	30.00	1.0027	32.00	1.0695	34.00	1.1364
26.05	0.8707	28.05	0.9375	30.05	1.0043	32.05	1.0712	34.05	1.1380
26.10	0.8723	28.10	0.9392	30.10	1.0060	32.10	1.0729	34.10	1.1397
26.15	0.8740	28.15	0.9408	30.15	1.0077	32.15	1.0745	34.15	1.1414
26.20	0.8757	28.20	0.9425	30.20	1.0094	32.20	1.0762	34.20	1.1430
26.25	0.8773	28.25	0.9442	30.25	1.0110	32.25	1.0779	34.25	1.1447
26.30	0.8790	28.30	0.9459	30.30	1.0127	32.30	1.0795	34.30	1.1464
26.35	0.8807	28.35	0.9475	30.35	1.0144	32.35	1.0812	34.35	1.1481
26.40	0.8824	28.40	0.9492	30.40	1.0160	32.40	1.0829	34.40	1.1497
26.45	0.8840	28.45	0.9509	30.45	1.0177	32.45	1.0846	34.45	1.1514
26.50	0.8857	28.50	0.9525	30.50	1.0194	32.50	1.0862	34.50	1.1531
26.55	0.8874	28.55	0.9542	30.55	1.0211	32.55	1.0879	34.55	1.1547
26.60	0.8890	28.60	0.9559	30.60	1.0227	32.60	1.0896	34.60	1.1564
26.65	0.8907	28.65	0.9576	30.65	1.0244	32.65	1.0912	34.65	1.1581
26.70	0.8924	28.70	0.9592	30.70	1.0261	32.70	1.0929	34.70	1.1598
26.75	0.8941	28.75	0.9609	30.75	1.0277	32.75	1.0946	34.75	1.1614
26.80	0.8957	28.80	0.9626	30.80	1.0294	32.80	1.0963	34.80	1.1631
26.85	0.8974	28.85	0.9642	30.85	1.0311	32.85	1.0979	34.85	1.1648
26.90	0.8991	28.90	0.9659	30.90	1.0328	32.90	1.0996	34.90	1.1664
26.95	0.9007	28.95	0.9676	30.95	1.0344	32.95	1.1013	34.95	1.1681
27.00	0.9024	29.00	0.9693	31.00	1.0361	33.00	1.1029	35.00	1.1698
27.05	0.9041	29.05	0.9709	31.05	1.0378	33.05	1.1046	35.05	1.1715
27.10	0.9057	29.10	0.9726	31.10	1.0394	33.10	1.1063	35.10	1.1731
27.15	0.9074	29.15	0.9743	31.15	1.0411	33.15	1.1080	35.15	1.1748
27.20	0.9091	29.20	0.9759	31.20	1.0428	33.20	1.1096	35.20	1.1765
27.25	0.9108	29.25	0.9776	31.25	1.0445	33.25	1.1113	35.25	1.1781
27.30	0.9124	29.30	0.9793	31.30	1.0461	33.30	1.1130	35.30	1.1798
27.35	0.9141	29.35	0.9809	31.35	1.0478	33.35	1.1146	35.35	1.1815
27.40	0.9158	29.40	0.9826	31.40	1.0495	33.40	1.1163	35.40	1.1832
27.45	0.9174	29.45	0.9843	31.45	1.0511	33.45	1.1180	35.45	1.1848
27.50	0.9191	29.50	0.9860	31.50	1.0528	33.50	1.1197	35.50	1.1865
27.55	0.9208	29.55	0.9876	31.55	1.0545	33.55	1.1213	35.55	1.1882
27.60	0.9225	29.60	0.9893	31.60	1.0561	33.60	1.1230	35.60	1.1898
27.65	0.9241	29.65	0.9910	31.65	1.0578	33.65	1.1247	35.65	1.1915
27.70	0.9258	29.70	0.9926	31.70	1.0595	33.70	1.1263	35.70	1.1932
27.75	0.9275	29.75	0.9943	31.75	1.0612	33.75	1.1280	35.75	1.1949
27.80	0.9291	29.80	0.9960	31.80	1.0628	33.80	1.1297	35.80	1.1965
27.85	0.9308	29.85	0.9977	31.85	1.0645	33.85	1.1314	35.85	1.1982
27.90	0.9325	29.90	0.9993	31.90	1.0662	33.90	1.1330	35.90	1.1999
27.95	0.9342	29.92	1.0000	31.95	1.0678	33.95	1.1347	35.95	1.2015

For values not shown in the table, interpolate or use equation:

$$Rf = \sqrt{\frac{P_{flow}}{P_{base}}} = \sqrt{\frac{P_{flow}}{29.92}}$$

- P_{cf} = Pressure Conversion Factor
- P_{Base} = Assigned Base Pressure of 29.92" Hg Abs.
- P_{flow} = Laminar Inlet Pressure, " Hg. Abs.

The equation can be used up to and including two atmospheres absolute. It will be necessary to calibrate laminars for pressure exceeding above.

Appendix B

Air Particulate Sampling Field Log

Project Name: _____

Month: _____ Year: _____

Samplers: _____

Air Particulate Sampling Field Log

Date	Sample Number (use collect date)	Flow Rate (CFM)	+/- 10% Operational Range CFM Yes/No	Current Reading (hours/tenths)	Calculated Weekly Volume (ft ³)	Hour Meter Reset Yes/No	Comments (tears, water damage, dust loading, etc.) and Sampler Initials
I							
C							
I							
C							
I							
C							
I							
C							
I							
C							
I							
C							
I							
C							
I							
C							
I							
C							

I = install date

C = collect date

Sample # format: Mine Site – Station ID – Year/Month/Day – Media (example RH – 1 – 2008-02-26-F)

Conversion: LPM/28.3 = CFM

CFM x 28.3 = LPM

Appendix C

Completed Sample Chain-of-Custody Form



Paragon Analyticals

A Division of DataChem Laboratories, Inc.

225 Commerce Drive Fort Collins, CO 80524
800-443-1611 or (970) 490-1611 (970) 490-1622 Fax

Accession Number (LAB ID)

Chain-of-Custody Date 6/27/08 Page 1 of 1

Originator: Retain pink copy!

Project Name/No.: George/Ver Sampler(s): Joe Driller Turnaround (circle one) Standard or Rush (Due _____) Dispose: Date _____ or Return to Client _____

Report To: Joe Driller
 Phone: 307-856-8080
 Fax: _____
 E-mail: jdriller@strathmoreminerals.com
 Company: Strathmore Minerals
 Address: 2420 Watt Court
Riverton, WY 82501

Circle method (right); provide additional information as needed (comments).

Sample ID	Date	Time *	Lab ID	Matrix	Preservative	(Indicate type)	No. of Containers
GV-1-2008-06-06-F	6/6	0900		F	Ø	1	
GV-1-2008-06-13-F	6/13	1000		F	Ø	1	
GV-1-2008-06-20-F	6/20	1315		F	Ø	1	
GV-1-2008-06-27-F	6/27	0900		F	Ø	1	

STANDARD

* Time Zone: EST CST MST PST Matrix Key: O = oil, S = soil, NS = non-soil solid, W = water, L = liquid, E = extract, F = filter

Comments:
Composite with weekly samples from April and May, 2008.
Analyses to include Ra-226, Th-230, total U.
Composite sample label: GV-1-2008-QTR2

Relinquished By:	Signature <u>Joe Driller</u>	Printed Name <u>Joe Driller</u>	Date <u>6/27/08</u>	Time <u>1100</u>
Received By:	Signature _____	Printed Name _____	Date _____	Time _____

Form 2025.xls (4/6/04)

Appendix D

Radon Alpha Track Sampling Field Log

Project Name: _____

Month: _____ Year: _____

Samplers: _____

Radon Alpha Track Sampling Field Log

Date	Serial Number	Sample Number (use collection date)	Comments/Field Observations (sampler initials)
I			
C			
I			
C			
I			
C			
I			
C			
I			
C			
I			
C			
I			
C			
I			
C			
I			
C			
I			
C			

I = install date

C = collect date

Sample # format: Mine Site – Station ID – Year-Month-Day –Detector Label(example RH – 1 – 2008-02-26-A)

Appendix E

Exterior Radon Measurements Using Alpha-Track Detector Procedures Revision 1

Exterior Radon Measurements Using Alpha-Track Detector Procedures

Scope

This test method provides Strathmore's guidelines to determine the estimated exterior atmospheric radon concentration using alpha track-etch detectors. Included in this test method are procedures for ordering, storing, placing, retrieving, and shipping detectors and for exposing duplicate detectors.

Hazard Analysis

Safety shoes and safety glasses shall be worn while installing steel posts at the sampling locations.

No other hazards requiring controls have been identified. Site-specific controls may be available in the Health and Safety Plan for a particular project.

Terminology

Alpha track radon detector—A detector consisting of a plastic alpha track registration material enclosed in a filtered container. Alpha particles from radon and its decay products produce damage tracks on this material. The passive detector continually accumulates these damage tracks during the defined period of exposure. The density of the tracks is proportional to the radon exposure.

Duplicate detectors—Detectors deployed in the field and mounted immediately adjacent to the primary detector. Analytical results of the duplicate detector(s) will be compared to the analytical results of the primary field detector. The degree of variability of the analytical results between the primary detector and the duplicate detector(s) will be assessed. A high degree of variability between detectors may require the implementation of blank detectors, control detectors, and a review of laboratory QA/QC procedures. Procedures for determining variability are presented in Section 12, Precision and Bias, of this document.

Integrating detector—An instrument designed to estimate the cumulative exposure to radon or radon decay products in an atmosphere.

Significance and Use

Atmospheric concentrations of radon-222 (Rn-222) are monitored in the vicinity of uranium mining operations to provide a database for assessing exposures from mining operations. Alpha track radon monitors are one type of device used to measure atmospheric Rn-222. Exterior radon measurements also are used for routine environmental monitoring.

Interferences

The alpha-track registering material is sensitive to alpha particles from any source. However, the alpha-track radon detector is calibrated only for exposure to Rn-222. It is important to inspect the detector filter before and after exposure because a damaged filter can allow radon decay products

and radionuclides other than Rn-222 to enter the detector. Most commercial filters do not eliminate short lived gaseous alpha emitters like thoron. However, because of thoron's short half life (55.6 seconds) and associated short migration distance, it is generally considered an inconsequential constituent of air that is more than several centimeters above ground level.

Because the detectors are integrating devices, care must be taken to prevent exposing detectors to radon during shipping, storage and field deployment. Any radon entering the detectors before or after the scheduled exposure will produce tracks that are indistinguishable from tracks registered during the exposure time period. For this reason, the detectors will remain sealed in the laboratory provided aluminum envelope and individual detector packaging until the detectors are deployed in the field.

Apparatus

The following equipment and supplies are required:

- Exterior alpha-track radon detectors and various accessories needed to assemble the detectors
- Environmental enclosures
- Field notebook
- Fence post driver
- Site map
- Steel T-posts or fence post, 5 feet in length
- Steel hose clamps
- Screwdriver
- Personal protective equipment (e.g., safety glasses and safety shoes)
- Detector(s) in laboratory sealed aluminum envelope

Procedure for Ordering and Storing Detectors

Two weeks before the end of the quarterly monitoring period, order the required number of detectors that will be deployed in the field for the upcoming monitoring period. Upon receipt from the vendor, check the aluminum foil envelope for damage. Do not accept detectors in damaged packages. Store all detectors in the aluminum envelope and individual detector packaging unopened to reduce exposure to radon pending field deployment.

Procedure for Placing Detectors

The number of detectors placed, the frequency of replacement, and the location and quantity of sampling locations (including background sampling locations) will be determined on a site-specific basis.

The following steps are required to place the detectors:

1. When selecting sampling locations, consider prevailing wind patterns, population distributions, and previous atmospheric radon monitoring measurements. Select sampling locations that minimize the risk of damage to the detectors from traffic, vandalism, and animals rubbing against the steel T-post(s) or fence post(s). When possible, establish one of the background sampling locations in an area that is unpopulated, upwind from the

site, away from effects of industrial atmospheric pollution, and representative of the local geology.

2. At the sampling location, drive a 5-foot steel T-post into the ground using a fence post driver. Similarly, an established fence post can be used.
3. Record the sampling location and location number on a map of the site.
4. Remove the alpha-track radon detector from the sealed aluminum envelope and then from the sealed wrapping material. Deploy the detector in the field the same day its sealed wrapper is opened.
5. Inspect the detector. Do not use any detector with a filter that is cracked, torn, or separated from the edge of the detector.
6. Compare the serial number on the detector with the number on the package. If necessary, use permanent ink to correct the number on the package so that it agrees with the number on the detector. Save the aluminum envelope and detector wrapping packaging.
7. Place any accessories on the detector according to the instructions supplied by the vendor.
8. Record the detector's serial number, date of installation, and sampling location in the field notebook.
9. Place the detectors in the protective environmental enclosure. The interior of the environmental enclosures may vary depending on the geometry of the alpha-track radon detector used.
10. Secure the environmental enclosure containing the alpha-track radon detector to the T-post with a steel hose clamp or to a fence post at 1 meter above ground level with the open side facing down. This step may vary according to the type of detector and the vendor's instructions.
11. Place detectors in triplicate (to improve precision and to assess variability) at all sampling locations for a period of at least 3 months.
12. Repeat Steps 3 through 12 for all sampling locations. Sign and date the bottom of each page of the field notebook where new entries were made.

Procedure for Retrieving Detectors

The following steps are required to retrieve the detectors:

1. Unscrew wing nuts, remove plastic retaining ring from environmental enclosure.
2. Remove the alpha-track radon detector from the holder. Inspect the detector for damage. Note its condition in the field notebook. Affix the laboratory-provided gold circle seal over the open end of the detector.

3. Record the retrieval date on the Radon Test Detector Log and in the field notebook and verify that the detector's serial number and the sampling location are correct.
4. Seal and/or pack the detector as recommended by the vendor.
5. Install the replacement detector(s) according to Section 9 if monitoring is to be continued.
6. If monitoring is complete, remove the environmental enclosure and T-post from the sampling location.
7. Repeat Steps 1 through 7 for all sampling locations. Sign and date the bottom of each page of the field notebook where new entries were made.
8. Store all exposed detectors in the detector packaging and aluminum envelope until they are shipped to the vendor.

Procedure for Shipping Detectors

The following steps are required to ship the detectors:

1. Collect all field and duplicate detectors. Add the date removed to the Radon Test Detector Log sheet and to the field notebook.
2. Package the detectors according to the vendor's instructions using the detector wrapping material and aluminum foil envelope
3. Complete the Radon Test Detector Log sheet using data from the field notebook, showing the detector's serial number, the exposure starting date, exposure ending date, and Strathmore sample number (see section 3.2 Radon Detectors of Air Monitoring SAP protocol). The original (white copy) accompanies the detectors back to the laboratory. Retain the duplicate Radon Test Detector Log (yellow copy) for Strathmore's files.
4. Complete the appropriate procurement paperwork. Have the detectors analyzed at the vendor's most precise level of sensitivity. The following values must be requested from the vendor: total tracks counted, average net tracks per square millimeter, net radon exposure in picocurie days per liter, average radon concentration in picocuries per liter, and calibration factor in tracks per square millimeter per picocurie days per liter and the batch number used.
5. Ship detectors by next day express service.

Documentation and Records

Keep copies of the vendor's report, any calculations, data information sheets, and data from exposure of control detectors in the working file.

Send originals of the vendor's report, calculations, data information sheets, Radon Detector Log Sheet, and completed field notebooks to permanent project file.

Precision and Bias

The precision of the mean of the alpha-track measurements can be estimated from the results of the concurrently exposed field detectors. The best estimate of the precision is obtained from the standard error of the mean (SE):

$$SE = \frac{1.253s}{\sqrt{n}}$$

where

s = sample standard deviation; and
n = number of concurrently exposed detectors (i.e., 2).

References

Rangel, M. J., M. D. Pearson, and G. H. Langner, Jr., 1988, "Radon-Free Chamber" in Abstracts of Papers Presented at 33rd Annual Meeting of the Health Physics Society, Boston, Massachusetts, July 4–8, Pergamon Press, New York, New York.

Appendix F

Environmental Gamma TLD Sampling Field Log

Project Name: _____

Month: _____ Year: _____

Samplers: _____

Environmental Gamma TLD Sampling Field Log

Date	Serial Number	Sample Number	Comments/Field Observations (sampler initials)
I			
C			
I			
C			
I			
C			
I			
C			
I			
C			
I			
C			
I			
C			
I			
C			
I			
C			
I			
C			
I			
C			

I = install date

C = collect date

Sample # format: Mine Site – Station ID – Year-Quarter (QTR)-Dosimeter Label (example RH – 1 – 2008-QTR-1-Environmental)

Appendix G

Quarterly Air Sampler Calibration Log

